



Advanced Life Safety Solutionssm

BPS-602

BPS-802

BPS-1002

NAC Power Extenders

Application Guide

(See Installation Guide for additional information)



MEI
Approved

1. General Information (Use this in conjunction with respective Installation Guide):

Mircom BPS-602, BPS-802 and BPS-1002 are very versatile devices. They can be used with or without specific synchronization modules provided by some manufacturers. Multiple units can be synchronized by using either the built-in sync mode or a external synchronization module. Please note, that only notification appliances with synchronization capabilities can be synchronized. Contact signal manufacturer for more detailed information.

Units can operate with either one (1) or two (2) outputs from the FACP. Two (2) outputs from the NAC power extender can be paralleled to achieve up to 4 amp, for circuits requiring additional power.

Note: Each output can be split into two (2) loops to achieve up to eight (8) Class B circuits.

2. Paralleling Two (2) Outputs:

To parallel two (2) outputs for maximum NAC capability of 4 amp, bridge (pos+) to (pos+) and (neg-) to (neg-) (ex. +OUT3 to +OUT4 and OUT3 - to OUT4 -, Fig. 2). Both of the corresponding output switches must be set the same way. Install two (2) 2.2K ohm EOL resistors in parallel across the last notification appliance. Please note: Paralleled output circuit configuration is not power limited and paralleling is not allowable for Class A configuration.

Fig. 2

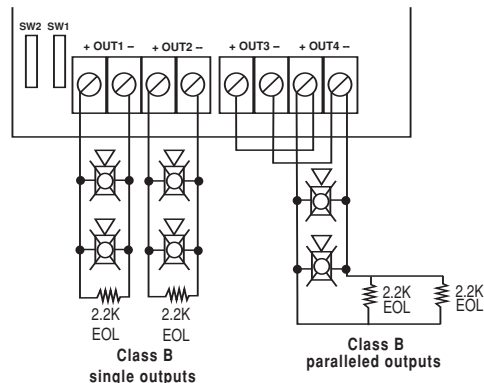

3. Class A and Class B Hookups:

Units can be used with the outputs configured for:

- Two (2) Class A (Fig. 3A).
- Two (2) Class B and one (1) Class A NAC circuits (Fig. 3B).
- Up to Eight (8) Class B (Fig. 3C).

Fig. 3A

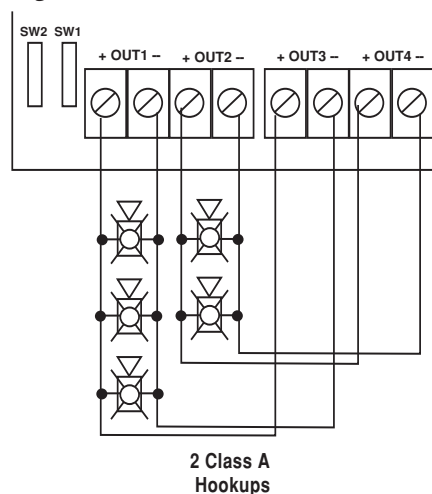

NAC Loop 1 starts on Output 1 and terminates on Output 3. Switch SW1, when closed, provides proper termination for this loop. NAC Loop 2 starts on Output 2 and terminates on Output 4, SW2 must be closed for proper termination. Please make sure that all the dip switches for corresponding outputs are set the same way.

Fig. 3B

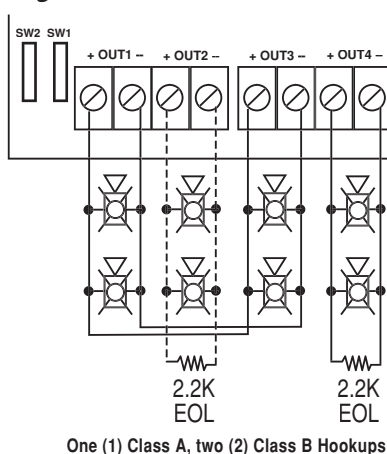

For combination of two (2) Class B and one (1) Class A circuit, only one (1) switch (SW1 or SW2) must be closed, terminating Class A circuit only.

Fig. 3C

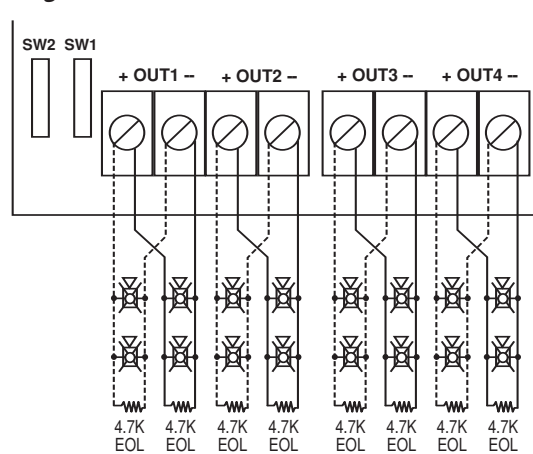

Eight (8) wire runs

Connect two (2) wire runs to one (1) output with a 4.7K EOL used to terminate each wire runs.

Note: Both wire runs will be supervised. A trouble condition on either wire run is reported on the common signaling circuit. However a short circuit on one wire run will affect the other wire run on the same signaling circuit. Keep wires on different sides of the screw. DO NOT USE one (1) continuous circuit around the terminal. This is available to facilitate more wire runs from the unit.

4. Non-synchronizable NAC Appliances:

When using NAC appliances not designed to support synchronization feature, it is recommended to use separate output circuits for audible notification appliances (horns) and visual notification appliances (strobes). Set dip switches for the visual notification appliances to follow Input 1 [IN1] and for audible notification appliances to follow Input 2 [IN2]. This will allow, when using two (2) outputs from the FACP, to support silencing of audible notification appliances. When using only one (1) FACP output, set all dip switches to follow Input 1 [IN1]. The units outputs can each be set for the desired NAC drive signal, such as Code 3 or march time sequence (*Output Programming Selection Table, pg. 6*). Non-synchronizable Audible Appliances will follow the sequence, when feature is selected.

5. Synchronizing One (1) or More NAC Power Extenders from an FACP with Sync Capability or a Sync Module:

BPS-602, BPS-802 and BPS-1002 units are designed to follow (replicate) the coded sequence, generated by a manufacturer's sync module. One (1) or more units can be synchronized. Please select Input to Output follower mode (*Output Programming Selection Table, pg. 6*). Connect the output of the sync module to Input 1 or Input 2, depending which input is selected to drive the outputs. Terminate the input circuit with the EOL, connecting it to terminals marked [RET+ and RET-], or continue the input circuit, connecting to terminals marked [RET+ and RET- to INP+ and INP-] of the next unit, when multiple units need to be synchronized.

Fig. 5

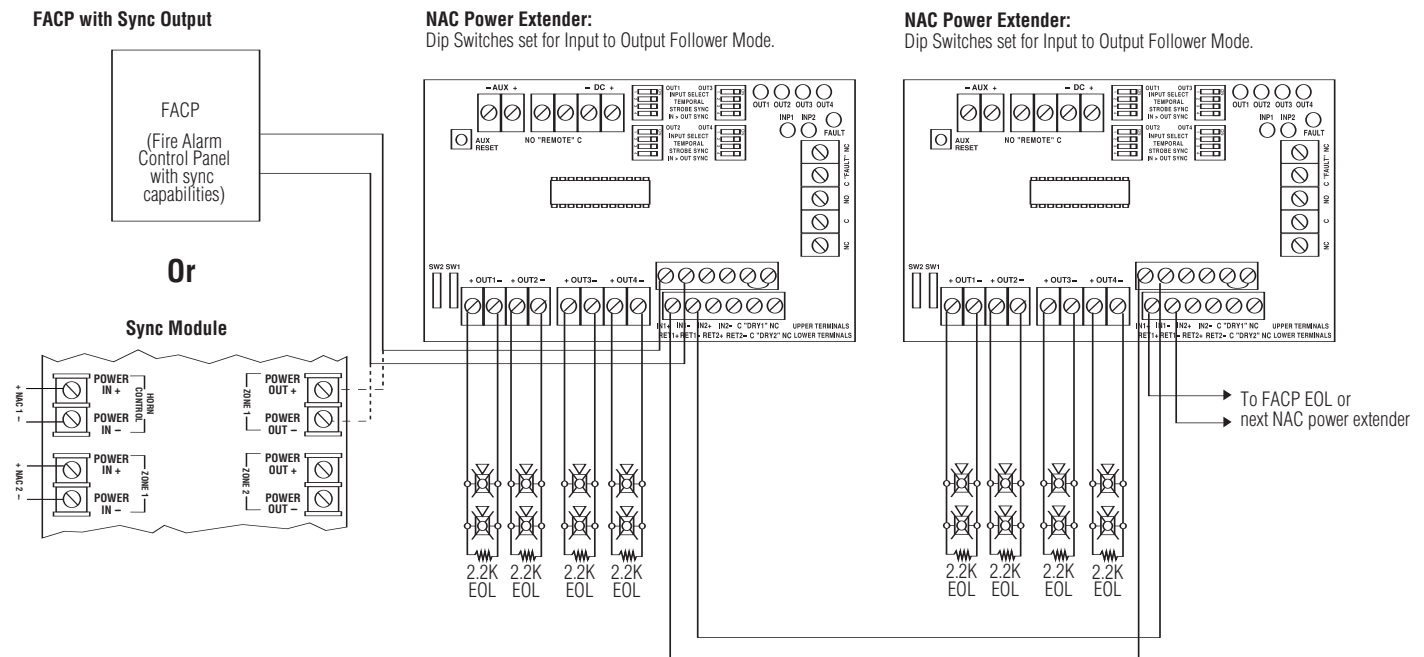

6. Synchronizing One (1) or More NAC Power Extenders Using Built-in Sync Protocol:

BPS-602, BPS-802 and BPS-1002 have built-in protocols to support Amseco, Faraday, Gentex® and System Sensor® two-wire synchronizable devices, therefore an external sync module is not required (*Output Programming Selection Table, pg. 6*). In these modes, Input 1 is always used to activate visual notification appliances (strobes), and Input 2 is used to activate and silence audible notification appliances (strobes).

Note: Input 1 has to be activated in all the configurations.

Multiple NAC Power Extenders can be synchronized by one (1) of two (2) (*Figs. 6A and 6B*) methods described below: Set the master unit to generate the desired sync protocol, while the remaining NAC Power Extenders are set for Input/Output Follower Mode.

Fig. 6A

For continuous loop circuit use 2.2K EOL.

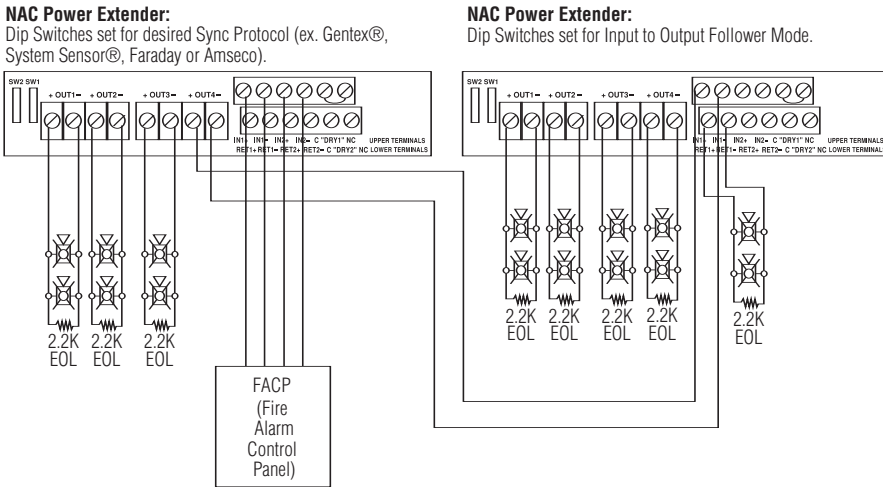
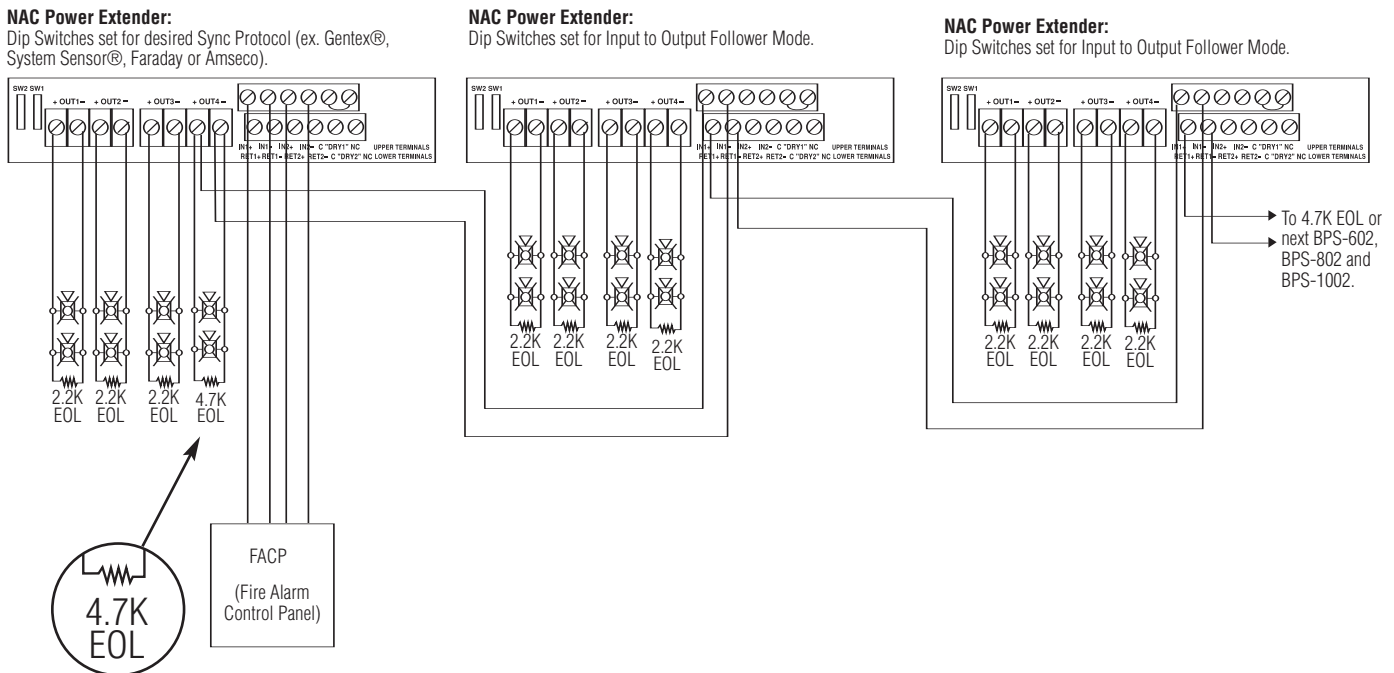

Fig. 6B

For split output circuit use 4.7K EOL.



When connecting, keep wires on different sides of the screws in order to maintain loop integrity supervision. **DO NOT LOOP CONTINUOUS WIRE AROUND THE SCREW.**

7. Using a Single FACP Output:

When only one FACP output is available, you may connect both Input1 and Input2 to it. Wire [RET1+ and RET1- to INP2+ and INP2-]. Both visual and audible notification appliances will be activated simultaneously (*Fig. 7*).

Fig. 7A

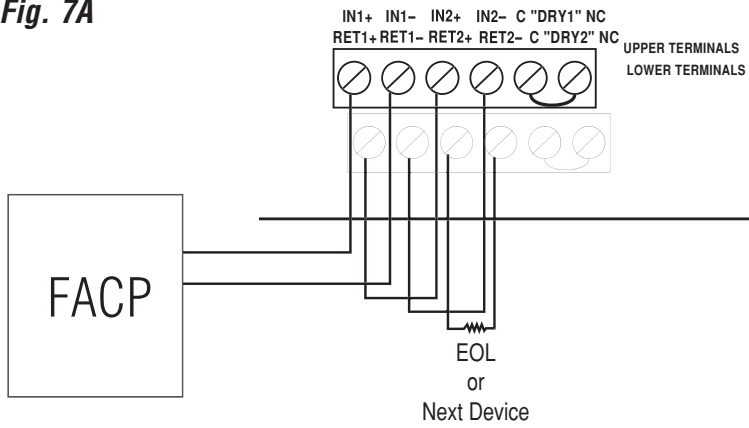

Output Programming Selection Table:

Outputs must be programmed independently (OUT1 - OUT4)

Function	Switch Positions		Descriptions
	ON	OFF	
Input to Output Follower Mode	1	2, 3	Output follows signal it receives from the corresponding input (i.e. FACP Sync module - maintains synchronization of notification appliance circuit.
Temporal Code 3 Mode	3	1, 2	Enables Temporal Code 3 signal generation output. This mode is activated by a steady or a pulsing input.
Steady Mode		1, 2, 3	A steady output signal will be generated. This mode is activated by a steady or pulsing input.
March Time Mode (60 beats per minute)	2, 3	1	Enables a March Time output which will sound 60 beats per minute. This mode is activated by a steady or pulsing input.

For the above modes Dip Switch 4 determines which Input controls the corresponding output:

Switch 4 in the ON position causes output(s) to be controlled by input 1.

Switch 4 in the OFF position causes output(s) to be controlled by input 2.

**(AL800LGK Board)
Output Dip Switches**

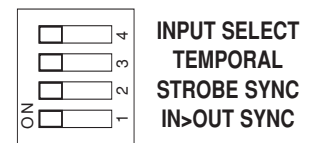

Sync Mode Selection Table:

Function	Switch Positions		Descriptions
	ON	OFF	
Amseco Sync Mode*	1, 3, 4	2	This mode is designed to work with the Amseco series of horns, strobes, and horn/strobes to provide a means of synchronizing the Temporal-coded horns, synchronizing the flash timing of the strobe, and silencing the horns of the horn/strobe combination over a two-wire circuit while leaving strobes active.
Faraday Sync Mode*	2, 4	1, 3	This mode is designed to work with the Faraday series of horns, strobes, and horn/strobes to provide a means of synchronizing the Temporal-coded horns, synchronizing the flash timing of the strobe, and silencing the horns of the horn/strobe combination over a two-wire circuit while leaving strobes active.
Gentex Sync Mode* <small>Gentex is a registered trademark of Gentex Corporation.</small>	1, 2, 3, 4		This mode is designed to work with the Gentex® Commander GOS and ST/HS series of horns, strobes, and horn/strobes to provide a means of synchronizing the Temporal-coded horns, synchronizing the flash timing of the strobe, and silencing the horns of the horn/strobe combination over a two (2)-wire circuit while leaving strobes active.
System Sensor Sync Mode* <small>System Sensor is a registered trademark of Honeywell.</small>	1, 2, 4	3	This mode is designed to work with the SpectrAlert™ series of horns, strobes, and horn/strobes to provide a means of synchronizing the Temporal-coded horns, synchronizing the one-second flash timing of the strobe, and silencing the horns of the horn/strobe combination over a two-wire circuit while leaving strobes active.

Note: The BPS-602, BPS-802, and BPS-1002 will only synchronize horns, horn strobes and strobes that contain synchronization capability. Contact signal manufacturer for more detailed info. The same synchronization mode must be selected for all outputs.

*** It is required to control visual notification appliances (strobes) via input 1 (IN1) and audible notification appliances (horns) via input 2 (IN2). This allows audible notification appliances (horns) to be silenced while visual notification appliances (strobes) continue to operate.**

Notes:

Notes:

Mircom is not responsible for any typographical errors.

USA - 60 Industrial Parkway, Cheektowaga (Buffalo), NY 14227, Canada - 25 Interchange Way, Vaughan (Toronto), ON L4K5W3
888-660-4655 • fax: 888-660-4113 • web site: www.mircom.com
Application Guide - BPS-602/BPS-802/BPS-1002

B15E