

QMP-5100B and QZP-5100 Series

Firefighters' Master Paging Module and Annunciator

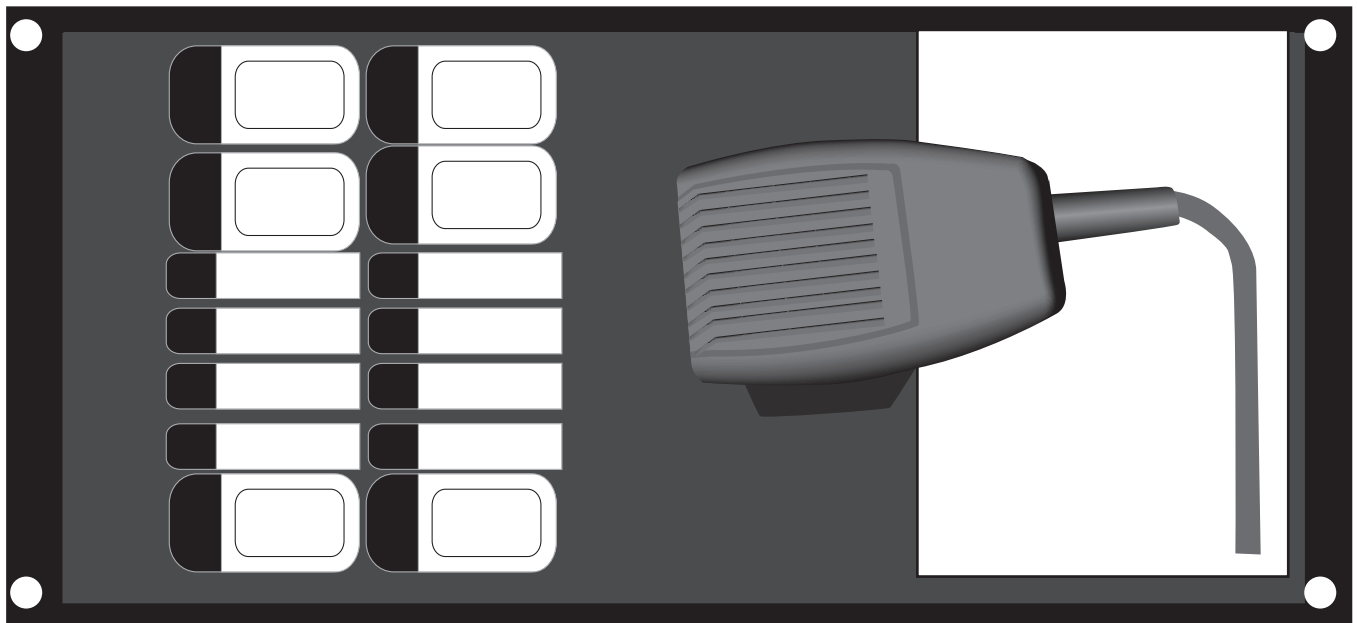

Contents

- QMP-5100B, QMP-5101B, QZP-5101, QZP-5102 and QZP-5103 Firefighters’
Master Paging Module System Installation, Wiring, And Operation Instruction 1**
 - Introduction 1
 - Mounting 1
 - Labels 1
- Paging Modules..... 2**
- Single Stage Operation..... 4**
- Two Stage Operation 4**
- QMP-5100B/QMP-5101B Paging Wiring 5**
 - QMP-5100B and QMP-5101B Paging Configuration..... 6
- Paging Operation 7**
 - QMP-5100B/QMP-5101B Displays 7
 - QMP-5100B/QMP-5101B Controls 7
- Warranty & Warning Information 8**
 - Warning Please Read Carefully 8
 - Limited Warranty 10
 - Warranty Procedure 10
 - Disclaimer of Warranties 10
 - Out of Warranty Repairs 11

QMP-5100B, QMP-5101B, QZP-5101, QZP-5102 and QZP-5103 Firefighters' Master Paging Module System Installation, Wiring, And Operation Instruction

Introduction

MIRCOM's FireFighters' Master Paging Module System is used as a Multi-Zoned System (with the QZP-5101, QZP-5102 and QZP-5103 Paging Selector Panels).

Mounting

The modules mount in any of the BB-1000 Series Remote Annunciator enclosures except for the QMP-5101B which mounts into a BB-5008 or BB-5014 backbox. For the QMP-5100B Master Paging Module, the included extended window module must be installed in place of the existing window. In any BB-1000 enclosure, the QMP-5100B is mounted bottom-most, and one to five QZP Selector Panels above, for up to 120 Audio Paging Zones for ease of ribbon cable connection.

Labels

Slide-in labels which are supplied with the QMP-5100B and QMP-5101B as NP-776 (E1 & E2 English or F1 & F2 French) are to be separated and inserted into the appropriate pockets. The QZP-5101 includes blank labels for Audio Paging Zone information.

Chassis Ground

Connect at least one of the BB-1000 Series, BB-5008 or BB-5014 backboxes' Earth-Ground points (Chassis Ground) to Earth Ground (cold water pipe).

Power Supply

Only the master paging QMP-5100B or QMP-5101B module requires power, 24 VDC, 200 mA DC from QIF-5000B J2, Terminals 7 & 8.

Connectors

On the QMP-5100B and QMP-5101B, P3 is the connection for the Master Paging Module to the QZP-5101. On the QZP-5101, P1 connects to the Master Paging Module (QMP-5100B or QMP-5101B) or the previous QZP Selector Panel, and P2 connects to the next QZP Selector Panel. The QZP-5102 has two special cables, refer to cable diagram packed with the unit for proper installation instruction.

Paging Modules

The QMP-5100B Master Paging Module has a ribbon cable connection to the first QZP-5101 Zone Selector Module, and wiring terminals for connection to the QIF-5000B Interface Module in the Audio Cabinet and to the QMT-5300A or QMT-5302 Telephone Master.

The two DIP Switches, SW1 & SW2 are for configuration. **There are no field configurable jumpers or potentiometers to adjust; these should be left alone with their factory default settings.**

Figure 1: QMP-5100B Master Paging Module

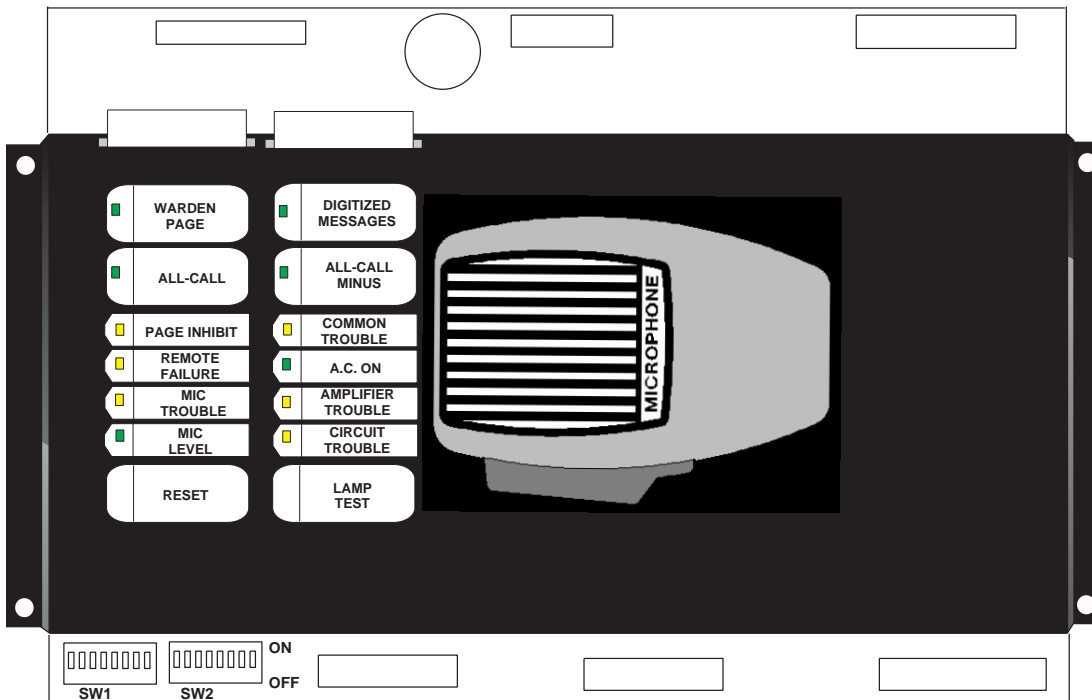

See also the section *Paging Operation*.

The QMP-5101B Master Paging Module has a ribbon cable connection to the first QZP-5101 Zone Module, and wiring terminals for connection to the QIF-5000B Interface Module in the Audio Cabinet and to the QMT-5300A or QMT-5302 Telephone Master.

The two DIP Switches, SW1 & SW2 are for configuration. **There are no field configurable jumpers or potentiometers to adjust; these should be left alone with their factory default settings.**

Figure 2: QMP-5101B Master Paging Module

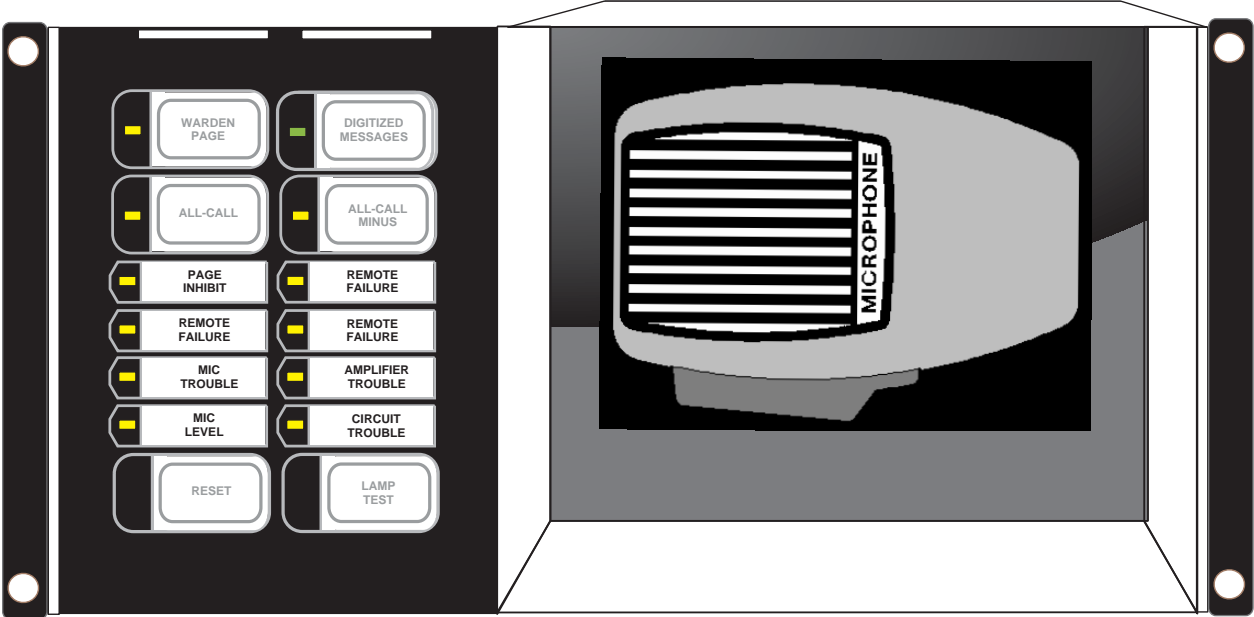
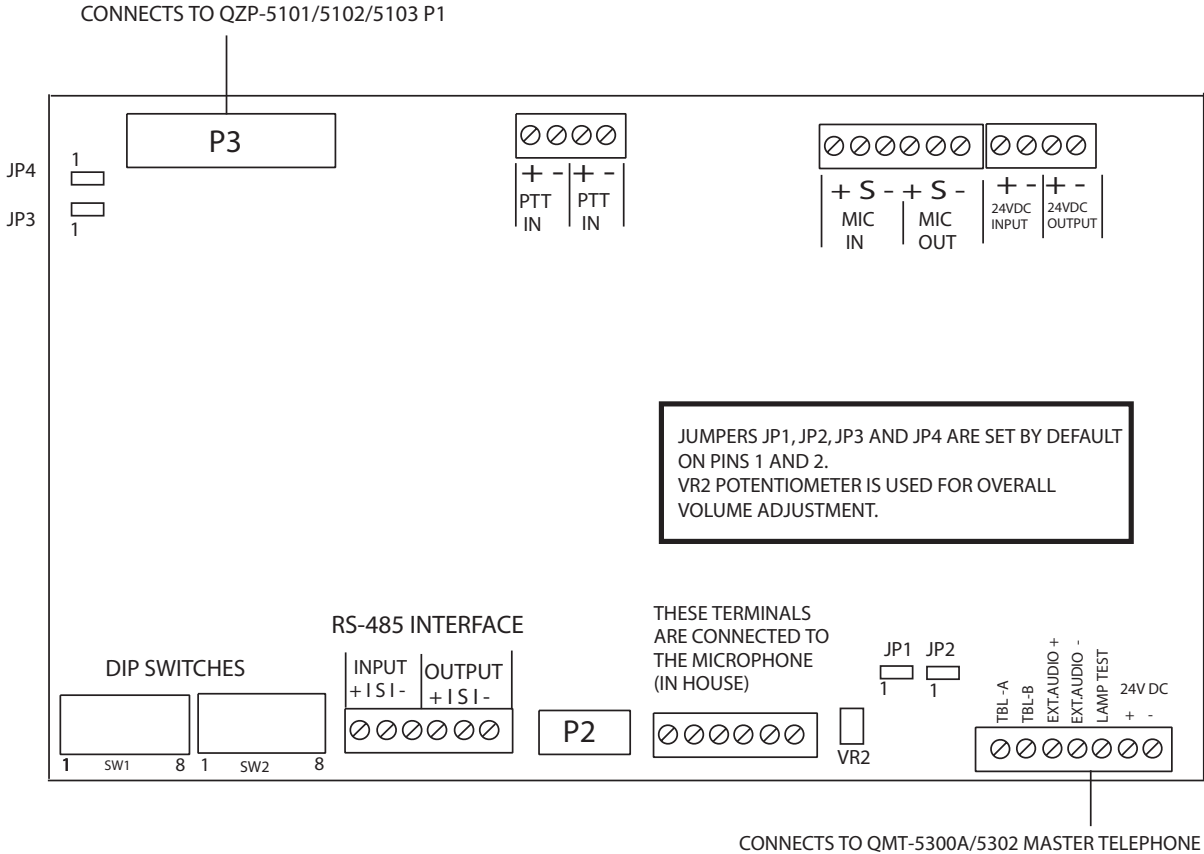

Figure 3: QMP-5100B and QMP-5101B Master Paging Module Connections and Location of DIP Switches and Terminal Blocks



Single Stage Operation

Each QZP-5101 annunciates and controls up to 24 Audio Zones. There are one button and two LEDs per Zone. The lower amber LED indicates Zone Trouble. The upper green LED indicates whether that Zone is selected for Voice Paging via the Master Microphone.

The button turns the selection for Voice Paging for that Zone ON and OFF.

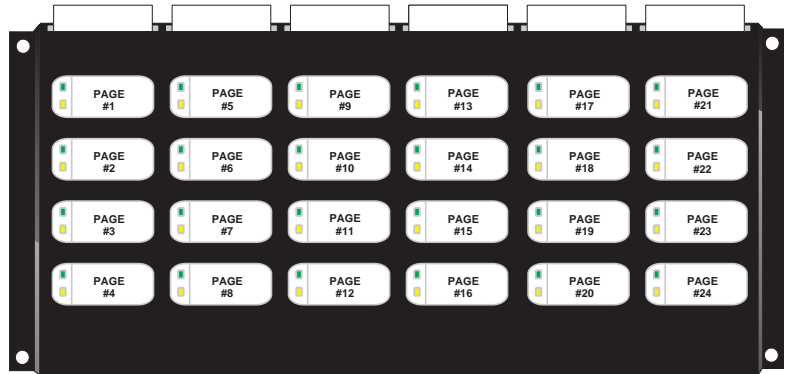

Note: For current production use QZP-5101 to function as QZP-5102 and/or QZP-5103.

Two Stage Operation

The QZP-5102 is used for two-stage operation with alert and evacuation tones. Each QZP-5102 annunciates and controls up to 12 Audio Zones. There are one button and two LEDs per Zone. The top green LED indicates whether that Zone is selected for Voice Paging. The amber bottom LED indicates Zone Trouble. The button labelled Page turns the selection for Voice Paging for that Zone ON and OFF.

A special cable is required for connection to the Fire Alarm Control Panel, see installation sheet packed with the QZP-5102.

Each QZP-5103 annunciates and controls up to 12 Audio Zones. There are two buttons and three LEDs per Zone. The middle amber LED beside the top button indicates Zone Trouble. The upper green LED by the top button indicates whether that Zone is selected for Voice Paging. The bottom red LED by the button labelled EVAC for each Zone indicates whether the Evacuation Tone is being sent to that Zone.

The top button for each Zone turns the selection for Voice Paging for that Zone ON and OFF.

The bottom button (EVAC) for each Zone turns the selection for Evacuation ON

(latching) for that Zone. It may be overridden by the paging, by selecting the Page zone and pushing the microphone PTT (Push to Talk) button.

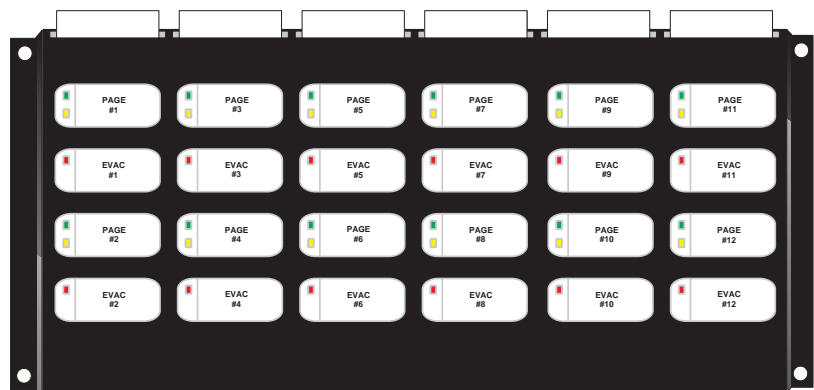
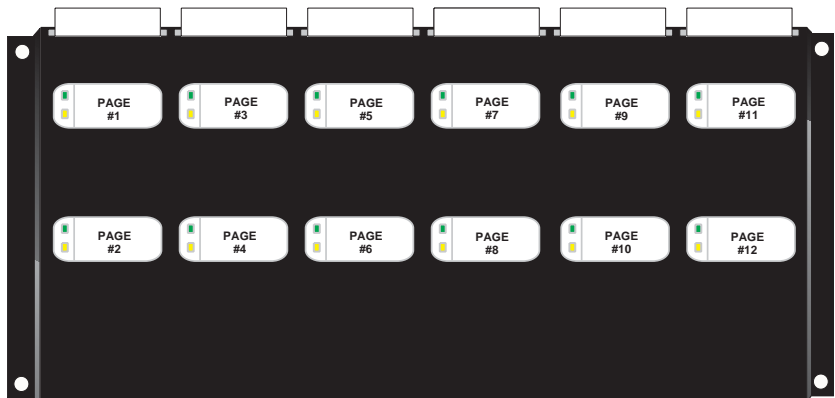

QMP-5100B/QMP-5101B Paging Wiring

The wiring connection between the QMP-5100B/QMP-5101B Master Paging Module in Lobby Panel and the QIF-5000B Interface Module in the Audio Cabinet, is shown below.

QMP-5100B/QMP-5101B to QIF-5000B Wiring

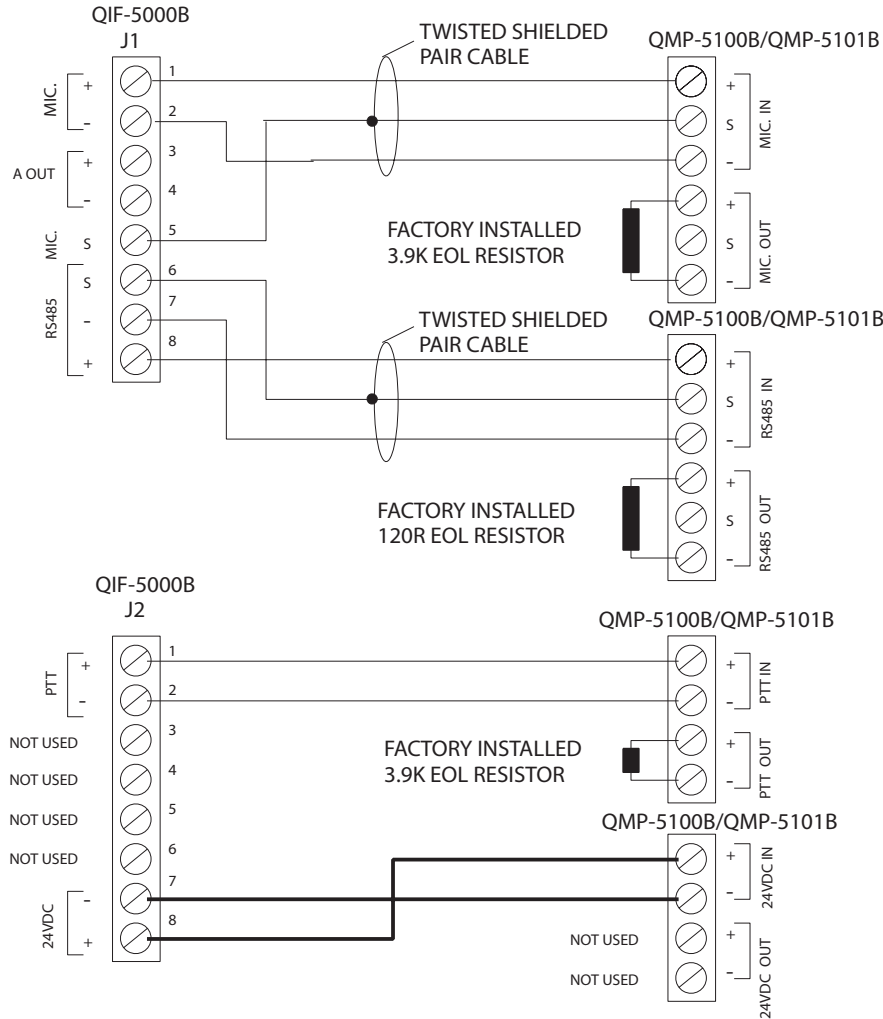

NOTE: WIRE OUTPUT FROM THE QIF-1000 (IF USED) TO AOUT INPUT TERMINALS ON THE QIF-5000B. REFER TO THE QIF-1000 INSTRUCTION SHEET FOR SPECIFIC TERMINALS.

The interface wiring between the QIF-5000B and the QMP-5100B/QMP-5101B are as follows.

MIC+, MIC-, SHLD:	18-22 AWG Twisted Shielded Pair
RS485+, RS485-, SHLD:	18-22 AWG Twisted Shielded Pair
PTT+, PTT:	18-22 AWG Twisted Pair
24 VDC Power:	16 -18 AWG

The maximum wiring run from the QIF-5000B to the QMP-5100B/QMP-5101B is 1000 feet or 305 metres. All RS-485 must be point-to-point from the QIF-5000B, to the QMP-5100B or QMP-5101B. **No star-wiring or T-tapping is allowed.** The 120 ohm End-of-Line Resistor on the RS-485 Output terminals is removed on all except the last wired Module.

QMP-5100B and QMP-5101B Paging Configuration

As shown in previous figures, the QMP-5100B and QMP-5101B Configuration DIP Switches SW1 & SW2 are located on the bottom right corner of the module.



Note: "OFF" means the switch is in the off or open position, "ON" means it is in the on or closed position.

DIP Switch and Position	Function														
	DIP SWITCHES SW1-1 TO SW1-4 ARE USED FOR MULTIPLE QMP-5100Bs, ADDRESSES 1 TO 15 Note: For one QMP-5100B set Address at 1, since Address OFF, OFF, OFF, OFF = ERROR														
	1	2	3	4	5	6	7	8	9	10	11	12	13	14	15
DIP Switch SW-1	ON	OFF	ON	OFF	ON	OFF	ON	OFF	ON	OFF	ON	OFF	ON	OFF	ON
	OFF	ON	ON	OFF	OFF	ON	ON	OFF	OFF	ON	ON	OFF	OFF	ON	ON
	OFF	OFF	OFF	ON	ON	ON	ON	OFF	OFF	OFF	OFF	ON	ON	ON	ON
	OFF	OFF	OFF	OFF	OFF	OFF	OFF	ON	ON	ON	ON	ON	ON	ON	ON
	For Automatic All Call (when PTT is pressed), set to " ON ", otherwise leave " OFF "														
Microphone Pre-Announce Tone: " OFF " = No Tone, " ON " = Tone Present															
Master Telephone: " OFF " = Not Present, " ON " = Present															
Paging Selector Panel: ALWAYS "OFF"															
DIP Switch SW-2	Not used, must be left " OFF "														
	Not used, must be left " OFF "														
	Not used, must be left " OFF "														
	Not used, must be left " OFF "														
	Not used, must be left " OFF "														
	Not used, must be left " OFF "														
	Not used, must be left " OFF "														
	Not used, must be left " OFF "														

Paging Operation

This section describes the controls and indicators on the QMP-5100B and QMP-5101B Master Paging Modules.

QMP-5100B/QMP-5101B Displays

- **AC ON** Indicates that AC Power is present, green LED, illuminates steadily.
- **Common Trouble** Indicates any QX-5000 Trouble, flashes, amber LED.
- **Mic Trouble** Indicates a Microphone Trouble, flashes, amber LED.
- **Mic Level** Indicates the Paging Audio Level, green LED.
- **Amplifier Trouble** Indicates any QX-5000 Amplifier internal Trouble.
- **Circuit Trouble** Indicates any QX-5000 Amplifier field wiring Trouble.
- **Remote Failure** Indicates an RS-485 Communications Failure.
- **Page Inhibit** Indicates that Mic or Warden Paging is Inhibited.
- **Digitized Messages** Indicates that the Digitized Voice message is active, green LED, illuminates steadily.
- **All-Call** Indicates that the All-Call function is active, green LED, illuminates steadily. This LED will not function if the DIP Switch SW1-5 is set to ON.
- **All-Call Minus** Indicates that the All-Call Minus function is active, green LED, illuminates steadily. This LED will not function if the DIP Switch SW1-5 is set to ON.
- **Warden Page** Indicates that the Warden Page function is active, green LED, illuminates steadily.

QMP-5100B/QMP-5101B Controls

- **Reset** Performs a Reset of the QMP-5100B/5101B only (**not the fire alarm**).
- **Lamp Test** Momentarily activates all LED Indicators.
- **All-Call** Selects all Zones for Voice Paging. This button will not function if DIP Switch SW1-5 Automatic All-Call is set to ON.
- **All-Call Minus** Inverts the selection of Zones for Voice Paging. This button will not function if DIP Switch SW1-5 Automatic All-Call is set to ON.
- **Microphone PTT** The microphone's PTT (push-to-talk) button, when depressed, causes voice paging (from the microphone) to be enabled to all Zones selected for paging, unless Page Inhibit is active. **Note that pressing PTT will not result in any paging activity unless there are Zones selected for Paging.**
- **Warden Page** Causes voice paging from the Firefighters' Telephone (if connected) to be enabled to all Zones selected for paging. **Note that pressing PTT will not result in any paging activity. Note also that there must be an active Firefighters' Telephone connection for Warden Paging to occur.**
- **Digitized Messages** This button does not function.

Warranty & Warning Information

Warning Please Read Carefully

Note to End Users: This equipment is subject to terms and conditions of sale as follows:

Note to Installers

This warning contains vital information. As the only individual in contact with system users, it is your responsibility to bring each item in this warning to the attention of the users of this system. Failure to properly inform system end-users of the circumstances in which the system might fail may result in over-reliance upon the system. As a result, it is imperative that you properly inform each customer for whom you install the system of the possible forms of failure.

System Failures

This system has been carefully designed to be as effective as possible. There are circumstances, such as fire or other types of emergencies where it may not provide protection. Alarm systems of any type may be compromised deliberately or may fail to operate as expected for a variety of reasons. Some reasons for system failure include:

•*Inadequate Installation*

A Fire Alarm system must be installed in accordance with all the applicable codes and standards in order to provide adequate protection. An inspection and approval of the initial installation, or, after any changes to the system, must be conducted by the Local Authority Having Jurisdiction. Such inspections ensure installation has been carried out properly.

•*Power Failure*

Control units, smoke detectors and many other connected devices require an adequate power supply for proper operation. If the system or any device connected to the system operates from batteries, it is possible for the batteries to fail. Even if the batteries have not failed, they must be fully charged, in good condition and installed correctly. If a device operates only by AC power, any interruption, however brief, will render that device inoperative while it does not have power. Power interruptions of any length are often accompanied by voltage fluctuations which may damage electronic equipment such as a fire alarm system. After a power interruption has occurred, immediately conduct a complete system test to ensure that the system operates as intended.

•*Failure of Replaceable Batteries*

Systems with wireless transmitters have been designed to provide several years of battery life under normal conditions. The expected battery life is a function of the device environment, usage and type. Ambient conditions such as high humidity, high or low temperatures, or large temperature fluctuations may reduce the expected battery life. While each transmitting device has a low battery monitor which identifies when the batteries need to be replaced, this monitor may fail to operate as expected. Regular testing and maintenance will keep the system in good operating condition.

•*Compromise of Radio Frequency (Wireless) Devices*

Signals may not reach the receiver under all circumstances which could include metal objects placed on or near the radio path or deliberate jamming or other inadvertent radio signal interference.

•*System Users*

A user may not be able to operate a panic or emergency switch possibly due to permanent or temporary physical disability, inability to reach the device in time, or unfamiliarity with the correct operation. It is important that all system users be trained in the correct operation of the alarm system and that they know how to respond when the system indicates an alarm.

•*Automatic Alarm Initiating Devices*

Smoke detectors, heat detectors and other alarm initiating devices that are a part of this system may not properly detect a fire condition or signal the control panel to alert occupants of a fire condition for a number of reasons, such as: the smoke detectors or heat detector may have been improperly installed or positioned; smoke or heat may not be able to reach the alarm initiating device, such as when the fire is in a chimney, walls or roofs, or on the other side

of closed doors; and, smoke and heat detectors may not detect smoke or heat from fires on another level of the residence or building.

•*Software*

Most Mircom products contain software. With respect to those products, Mircom does not warranty that the operation of the software will be uninterrupted or error-free or that the software will meet any other standard of performance, or that the functions or performance of the software will meet the user's requirements. Mircom shall not be liable for any delays, breakdowns, interruptions, loss, destruction, alteration or other problems in the use of a product arising out of, or caused by, the software.

Every fire is different in the amount and rate at which smoke and heat are generated. Smoke detectors cannot sense all types of fires equally well. Smoke detectors may not provide timely warning of fires caused by carelessness or safety hazards such as smoking in bed, violent explosions, escaping gas, improper storage of flammable materials, overloaded electrical circuits, children playing with matches or arson.

Even if the smoke detector or heat detector operates as intended, there may be circumstances when there is insufficient warning to allow all occupants to escape in time to avoid injury or death.

•*Alarm Notification Appliances*

Alarm Notification Appliances such as sirens, bells, horns, or strobes may not warn people or waken someone sleeping if there is an intervening wall or door. If notification appliances are located on a different level of the residence or premise, then it is less likely that the occupants will be alerted or awakened. Audible notification appliances may be interfered with by other noise sources such as stereos, radios, televisions, air conditioners or other appliances, or passing traffic. Audible notification appliances, however loud, may not be heard by a hearing-impaired person.

•*Telephone Lines*

If telephone lines are used to transmit alarms, they may be out of service or busy for certain periods of time. Also the telephone lines may be compromised by such things as criminal tampering, local construction, storms or earthquakes.

•*Insufficient Time*

There may be circumstances when the system will operate as intended, yet the occupants will not be protected from the emergency due to their inability to respond to the warnings in a timely manner. If the system is monitored, the response may not occur in time enough to protect the occupants or their belongings.

•*Component Failure*

Although every effort has been made to make this system as reliable as possible, the system may fail to function as intended due to the failure of a component.

•*Inadequate Testing*

Most problems that would prevent an alarm system from operating as intended can be discovered by regular testing and maintenance. The complete system should be tested as required by national standards and the Local Authority Having Jurisdiction and immediately after a fire, storm, earthquake, accident, or any kind of construction activity inside or outside the premises. The testing should include all sensing devices, keypads, consoles, alarm indicating devices and any other operational devices that are part of the system.

•*Security and Insurance*

Regardless of its capabilities, an alarm system is not a substitute for property or life insurance. An alarm system also is not a substitute for property owners, renters, or other occupants to act prudently to prevent or minimize the harmful effects of an emergency situation.

IMPORTANT NOTE: End-users of the system must take care to ensure that the system, batteries, telephone lines, etc. are tested and examined on a regular basis to ensure the minimization of system failure.

Limited Warranty

Mircom Technologies Ltd. warrants the original purchaser that for a period of two years from the date of manufacture, the product shall be free of defects in materials and workmanship under normal use. During the warranty period, Mircom Technologies Ltd. shall, at its option, repair or replace any defective product upon return of the product to its factory, at no charge for labor and materials. Any replacement and/or repaired parts are warranted for the remainder of the original warranty or ninety (90) days, whichever is longer. The original owner must promptly notify Mircom Technologies Ltd. in writing that there is defect in material or workmanship, such written notice to be received in all events prior to expiration of the warranty period.

International Warranty

The warranty for international customers is the same as for any customer within Canada and the United States, with the exception that Mircom Technologies Ltd. shall not be responsible for any customs fees, taxes, or VAT that may be due.

Conditions to Void Warranty

This warranty applies only to defects in parts and workmanship relating to normal use. It does not cover:

- damage incurred in shipping or handling;
- damage caused by disaster such as fire, flood, wind, earthquake or lightning;
- damage due to causes beyond the control of Mircom Technologies Ltd. such as excessive voltage, mechanical shock or
- water damage;
- damage caused by unauthorized attachment, alterations, modifications or foreign objects;
- damage caused by peripherals (unless such peripherals were supplied by Mircom Technologies Ltd.);
- defects caused by failure to provide a suitable installation environment for the products;
- damage caused by use of the products for purposes other than those for which it was designed;
- damage from improper maintenance;
- damage arising out of any other abuse, mishandling or improper application of the products.

Warranty Procedure

To obtain service under this warranty, please return the item(s) in question to the point of purchase. All authorized distributors and dealers have a warranty program. Anyone returning goods to Mircom Technologies Ltd. must first obtain an authorization number. Mircom Technologies Ltd. will not accept any shipment whatsoever for which prior authorization has not been obtained. NOTE: Unless specific pre-authorization in writing is obtained from Mircom management, no credits will be issued for custom fabricated products or parts or for complete fire alarm system. Mircom will at its sole option, repair or replace parts under warranty. Advance replacements for such items must be purchased.

Note: Mircom Technologies Ltd.'s liability for failure to repair the product under this warranty after a reasonable number of attempts will be limited to a replacement of the product, as the exclusive remedy for breach of warranty.

Disclaimer of Warranties

This warranty contains the entire warranty and shall be in lieu of any and all other warranties, whether expressed or implied (including all implied warranties of merchantability or fitness for a particular purpose) And of all other obligations or liabilities on the part of Mircom Technologies Ltd. neither assumes nor authorizes any other person purporting to act on its behalf to modify or to change this warranty, nor to assume for it any other warranty or liability concerning this product.

This disclaimer of warranties and limited warranty are governed by the laws of the province of Ontario, Canada.

Out of Warranty Repairs

Mircom Technologies Ltd. will at its option repair or replace out-of-warranty products which are returned to its factory according to the following conditions. Anyone returning goods to Mircom Technologies Ltd. must first obtain an authorization number. Mircom Technologies Ltd. will not accept any shipment whatsoever for which prior authorization has not been obtained.

Products which Mircom Technologies Ltd. determines to be repairable will be repaired and returned. A set fee which Mircom Technologies Ltd. has predetermined and which may be revised from time to time, will be charged for each unit repaired.

Products which Mircom Technologies Ltd. determines not to be repairable will be replaced by the nearest equivalent product available at that time. The current market price of the replacement product will be charged for each replacement unit.

WARNING: Mircom Technologies Ltd. recommends that the entire system be completely tested on a regular basis. However, despite frequent testing, and due to, but not limited to, criminal tampering or electrical disruption, it is possible for this product to fail to perform as expected.

NOTE: Under no circumstances shall Mircom Technologies Ltd. be liable for any special, incidental, or consequential damages based upon breach of warranty, breach of contract, negligence, strict liability, or any other legal theory. Such damages include, but are not limited to, loss of profits, loss of the product or any associated equipment, cost of capital, cost of substitute or replacement equipment, facilities or services, down time, purchaser's time, the claims of third parties, including customers, and injury to property.

MIRCOM MAKES NO WARRANTY OF MERCHANTABILITY OR FITNESS FOR A PARTICULAR PURPOSE WITH RESPECT TO ITS GOODS DELIVERED, NOR IS THERE ANY OTHER WARRANTY, EXPRESSED OR IMPLIED, EXCEPT FOR THE WARRANTY CONTAINED HEREIN.

