

# DTC-300A

## Digital Transmitter Communicator

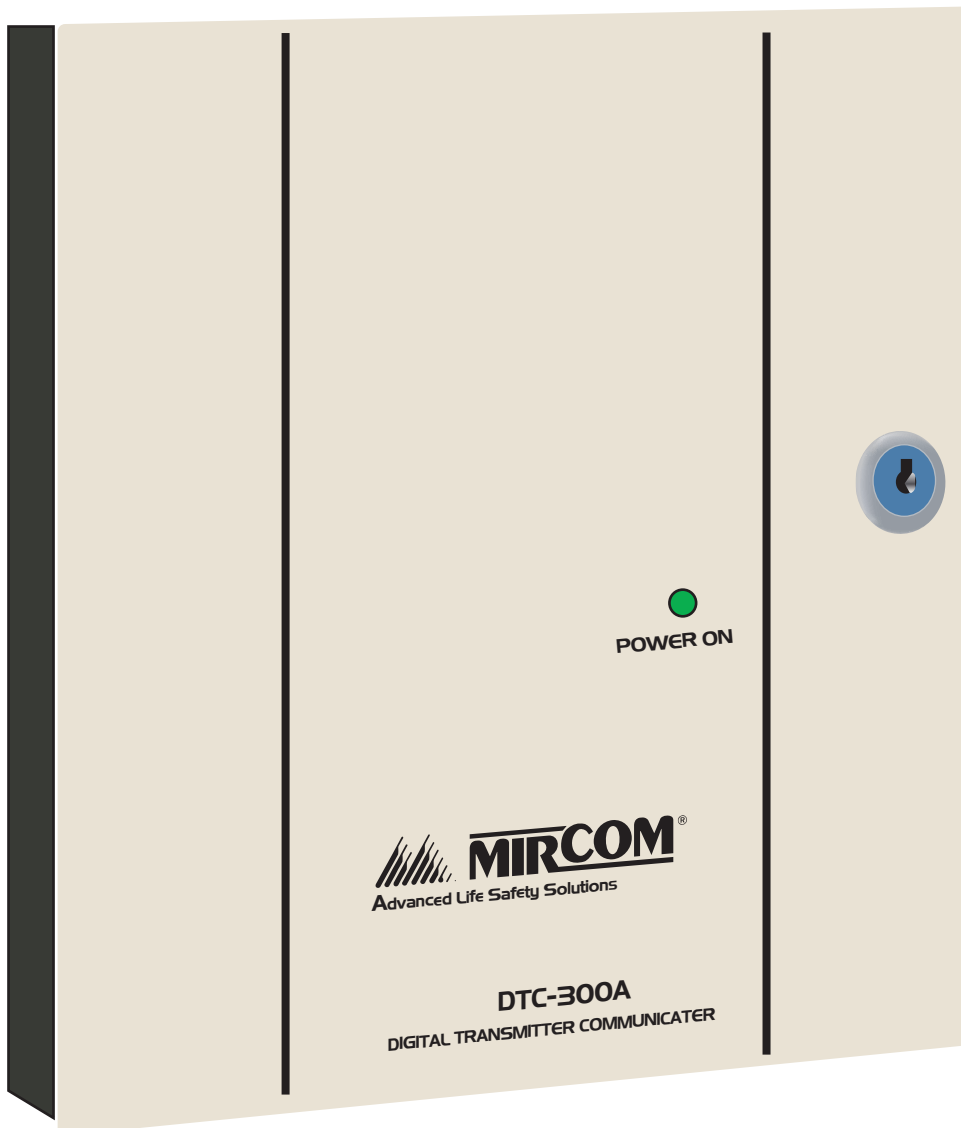



# Contents

---

<b>Industry Canada and FCC Notice .....</b>	<b>1</b>
<b>Introduction and Features .....</b>	<b>2</b>
<b>Mechanical Installation and Dimensions .....</b>	<b>3</b>
<b>Connections and Settings .....</b>	<b>4</b>
DTC-300A MAIN BOARD .....	4
<b>Field Wiring.....</b>	<b>6</b>
DTC-300A MAIN BOARD TELEPHONE WIRING .....	6
<b>Field Wiring (continued) .....</b>	<b>7</b>
DTC-300A MAIN BOARD INPUT ZONE WIRING .....	7
TROUBLE OUTPUT WIRING .....	8
POWER SUPPLY WIRING .....	9
<b>Power Up Procedures .....</b>	<b>9</b>
<b>Basic Operation and Supervision.....</b>	<b>10</b>
<b>Configuration Set-up .....</b>	<b>10</b>
CONFIGURATION VIA ON-BOARD KEYPAD .....	10
CONFIGURATION VIA UIMA AND COMPUTER(LOCAL): .....	10
CONFIGURATION VIA MODEM AND COMPUTER(REMOTE): .....	11
<b>Keypad Configuration &amp; Operation .....</b>	<b>12</b>
Entering the Passcode .....	12
Command Menu .....	13
1.View Event Log (Command-Menu).....	13
2. Clear Event Log (Command-Menu).....	14
3. Test Dialer (Command-Menu) .....	15
4. Config Info (Command-Menu) .....	17
5. Version Info .....	17
6. Set Time (Command-Menu) .....	17
7. Set Password (Command-Menu).....	18
8. Default Config (Command-Menu).....	19
9. Dialer Config (Command-Menu).....	19
10. Input Config.....	24
11. Exit .....	24
<b>Compatible Fire Alarm Control Panels .....</b>	<b>27</b>
<b>Compatible Receivers.....</b>	<b>27</b>
<b>Specifications.....</b>	<b>28</b>
<b>Battery Calculations .....</b>	<b>28</b>
<b>Warranty &amp; Warning Information.....</b>	<b>29</b>
Warning Please Read Carefully .....	29
Limited Warranty.....	31
Warranty Procedure.....	31
Disclaimer of Warranties .....	31
Out of Warranty Repairs .....	32



# Industry Canada and FCC Notice

## Notice for all DTC-300A Sold in the U.S.A.



**Note:** The Ringer Equivalence Number (REN) for this product is X.X.

Mircom's **DTC-300A Digital Communicator** described in this manual is listed by Underwriters Laboratories Inc. (ULI) under Standard 864 (Control Units for Fire Protective Signalling Systems). These Communicators comply with the National Fire Protection Association (NFPA) performance requirements for DACTs and should be installed in accordance with NFPA 72 Chapter 4 (Supervising Station Fire Alarm System). These Communicators should be installed in accordance with this manual; the National Electrical Code (NFPA 70); and/or the local Authority Having Jurisdiction (AHJ).

### FCC Notice

This equipment complies with the Federal Communications Commission (FCC) rules and regulations governing telephone equipment and the Technical Requirements for Connection to the Telephone Network published by the industry's Administrative Council for Terminal Attachments (ACTA). On the door of this equipment is a label that contains, among other information, a product identifier in the format **US:XXXXXXXXDTC-300A**. If requested, this number must be provided to the telephone company. This equipment is capable of seizing the line. This capability is provided in the hardware.

The Ringer Equivalence Number (REN) assigned to each terminal device provides an indication of the maximum number of devices that may be connected to a telephone line. Excessive REN's on a telephone line may result in the devices not ringing in response to an incoming call. In most, but not all areas, the sum of REN's should not exceed five (5.0). To be certain of the number of devices that may be connected to a line, as determined by the total REN's contact the local telephone company. **The REN for this product is X.X.**

**Telephone Company Procedures:** The goal of the telephone company is to provide you with the best service it can. In order to do this, it may occasionally be necessary for them to make changes in their equipment, operations or procedures. If these changes might affect your service or the operation of your equipment, the telephone company will give you notice, in writing, to allow you to make any changes necessary to maintain uninterrupted service.

In certain circumstances, it may be necessary for the telephone company to request information from you concerning the equipment which you have connected to your telephone line. Upon request of the telephone company, provide the FCC registration number and the ringer equivalence number (REN); both of these items are listed on the equipment label. The sum of all of the REN's on your telephone lines should be less than five in order to assure proper service from the telephone company. In some cases, a sum of five may not be usable on a given line.

**If Problems Arise:** If any of your telephone equipment is not operating properly, you should immediately remove it from your telephone line, as it may cause harm to the telephone network. If the telephone company notes a problem, they may temporarily discontinue service. When practical, they will notify you in advance of this disconnection. If advance notice is not feasible, you will be notified as soon as possible. When you are notified, you will be given the opportunity to correct the problem and informed of your right to file a complaint with the FCC. Contact your telephone company if you have any questions about your phone line. In the event repairs are ever needed on the Communicator, they should be performed by Mircom Technologies Ltd. or an authorized representative of Mircom Technologies Ltd. For information contact Mircom Technologies Ltd. at the address and phone numbers shown on the back page of this document.

## Introduction and Features

---

The DTC-300A is a single board Digital Communicator (DACT) that can connect to any Fire Alarm Control Panel (FACP). It can transmit Alarm, Supervisory, Waterflow Alarm, Common Trouble, AC power trouble and Battery Trouble information on two telephone lines to a Digital Alarm Communicator Receiver (DACR).

### Features:

- Scans up to 6 configurable input zones. The input zone type may be alarm, waterflow alarm, supervisory, trouble, AC trouble or Battery trouble.
- Reports to a DACR using **Ademco Contact ID** or **SIA DCS** reporting protocols.
- The DTC-300A has the ability of disconnecting the incoming and outgoing calls and capturing the line for transmission to the DACR.
- Provides telephone line monitoring and reports status via LED indication on-board.
- Provides LED indication for AC Power, Common Trouble, CPU Fail and Ground Fault.
- User configurable locally with on-board keypad and a **CFG-300 Configuration Tool** or using a UIMA and computer with serial port or USB. Remotely configurable via a personal computer, modem and telephone line connection.
- Provides event logs of 500 entries each to save events from local dialer or remote fire alarm panel. These logs can be reviewed locally with the CFG-300 Configuration Tool or remotely via modem.
- Requires 24V DC filtered or 24V DC Full Wave Rectified (FWR) power supply.

# Mechanical Installation and Dimensions

The **DTC-300A** board is a single PCB assembly. It comes mounted in a 8.25" wide by 9" high by 1.5" deep box. There are four mounting holes, two at the top and two at the bottom, see Figure 1 below for mounting hole location and backbox dimensions. There are two conduit holes at the top of the box and two conduit holes at the bottom of the box.

**Figure 1: DTC-300A Backbox Dimensions for Mounting**

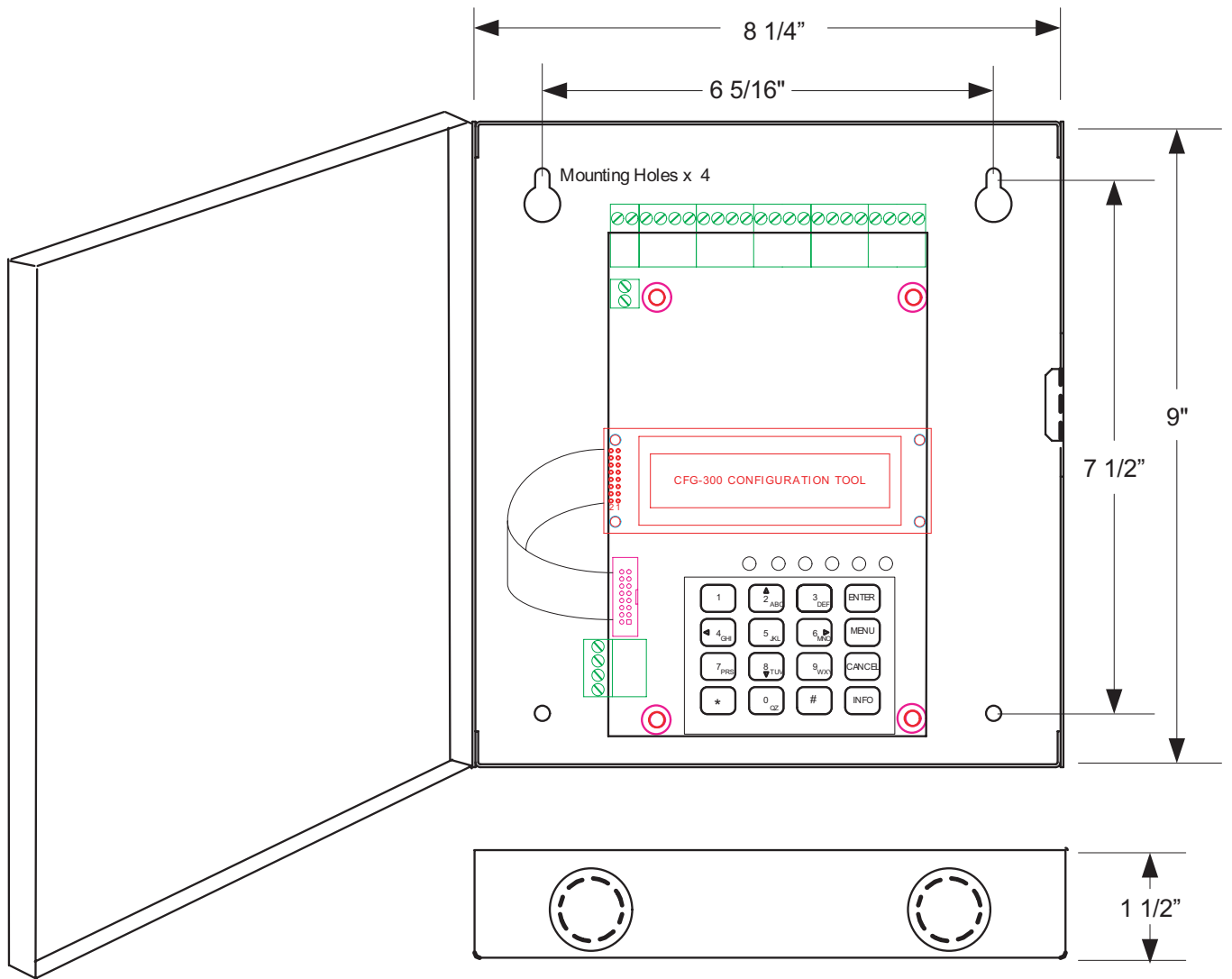

TOP AND BOTTOM

# Connections and Settings

## DTC-300A MAIN BOARD

There are FOUR jumpers on the DTC-300A for operation/configuration purposes and 8 LEDs for status indication. Jumper JW1 is used to reset the default passcode. Jumper JW2 is required for configuring the DTC-300A. Jumper JW3 is used for enabling/disabling Ground Fault detection and JW4 is used to set the Trouble Relay. Refer to Figure 2 for the location of jumpers, cable connections, pushbutton and LEDs. Table 1 provides a description of the status LEDs on the DTC-300A and Table 2 provides information on the use of jumpers JW1 to JW4.

**Figure 2: DTC-300A Board Layout**

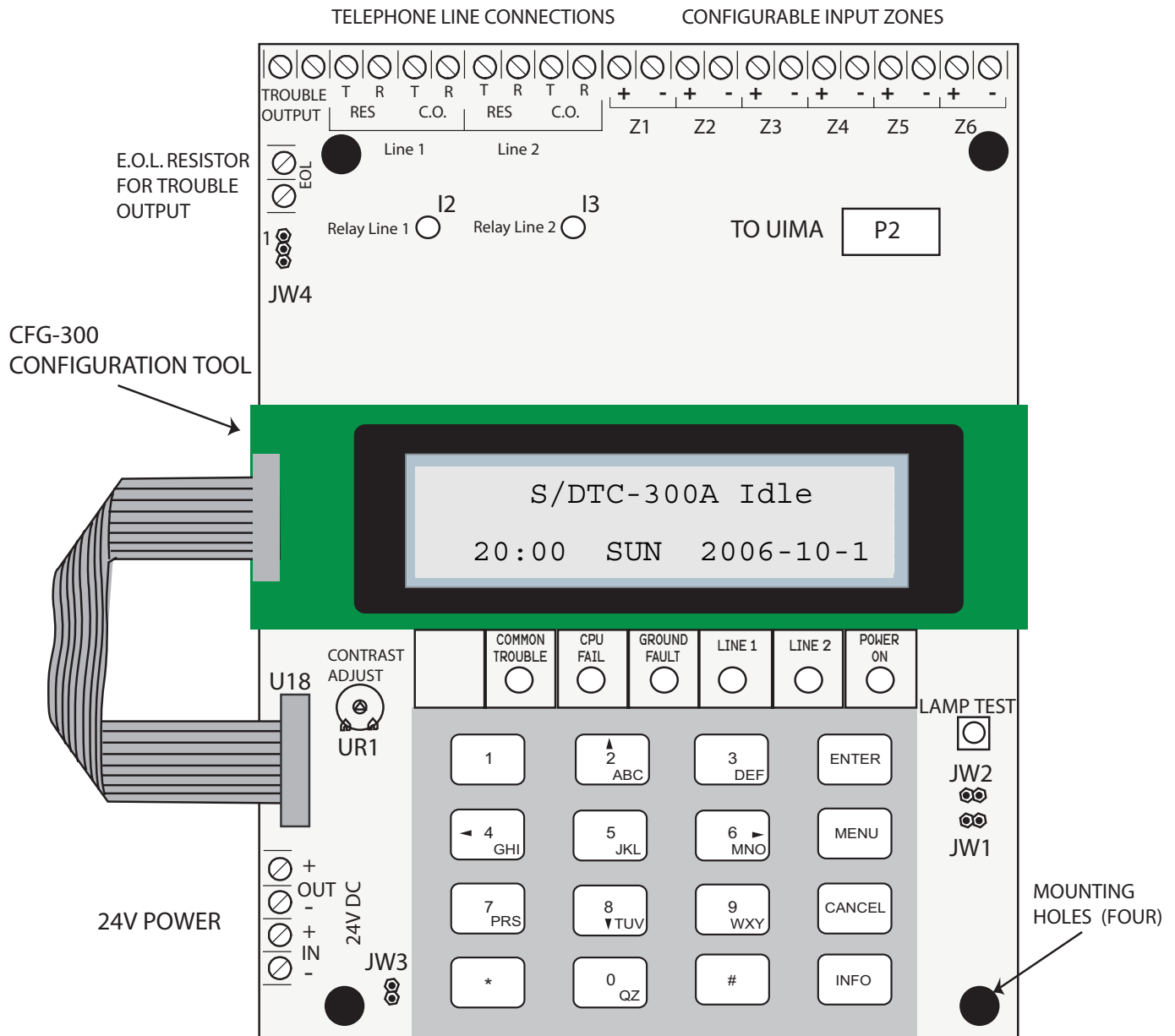

The following table lists all the LEDs located on the DTC-300A board and states the function of each LED.

**Table 1: DTC-300A List of LEDs and their Functions**

LEDs	FUNCTION
Relay Line 1	Located below Line 1 terminal block. When Line 1 relay is energized, this green LED will illuminate steady.
Relay Line 2	Located below Line 2 terminal block. When Line 2 relay is energized, this green LED will illuminate steady.
Common Trouble	Steady amber for any troubles on the DTC-300A and/or the Fire Alarm panel.
CPU Fail	Steady amber for any on board CPU trouble.
Ground Fault	Steady amber for any ground faults on the DTC-300A main board.
Line 1	Telephone Line 1 status indicator LED; Red steady when the line is in use, Amber steady when there is a line fault.
Line 2	Telephone Line 2 status indicator LED; Red steady when the line is in use, Amber steady when there is a line fault.
Power ON	Green LED is ON steady when power is supplied to the board.

The following table lists the user jumpers available on the DTC-300A and their functions.

**Table 2: DTC-300A List of Jumpers for Operation and Configuration**

JUMPER NUMBER	JUMPER FUNCTIONS
JW1	RESET PASSCODE: Default is normally open. TO RESET PASSCODE: Place jumper here and power down the DTC-300A by disconnecting the 24V power source or power down the fire alarm panel (AC and Batteries), then power back up to revert to the default passcode. After the passcode is reset, remove the jumper.
JW2	BLOCK REMOTE CONFIGURATION: Default is normally open to BLOCK remote configuration via modem, PC with a UIMA converter module or using the LCD and keypad at the DTC-300A. A trouble is initiated when the jumper is ON showing that the DTC-300A is in configuration mode. Place jumper here to ALLOW any type of configuration. Remove jumper once configuration is complete, trouble will restore.
JW3	GROUND FAULT DETECTION: Default has jumper pins normally shorted allowing ground fault detection on the DTC-300A. Remove this jumper to DISABLE ground fault detection (Ground Fault LED on the DTC-300A will not operate). The Fire Alarm Panel Ground Fault is not affected.
JW4	TROUBLE RELAY: Short pins 1 and 2 to select the TROUBLE OUTPUT relay contacts as normally closed(N.C.) or short pins 2 and 3 to select the TROUBLE OUTPUT relay contacts as normally open (N.O.). Default has pins 2 and 3 shorted, check fire alarm panel for proper setting required for the TROUBLE OUTPUT contacts.

# Field Wiring

## DTC-300A MAIN BOARD TELEPHONE WIRING

Wire the two telephone lines to RJ31X Connector terminals as shown in Figure 3 below. The DTC-300A telephone line terminals are located on the top left hand corner of the board. For a cellular or wireless service, use the Line 2 interface connection.



**Note:** Most Authorities Having Jurisdiction (AHJ) do not allow the connection of premise telephones. see specifications for more information.

**Figure 3: Telephone Line Wiring Diagram**

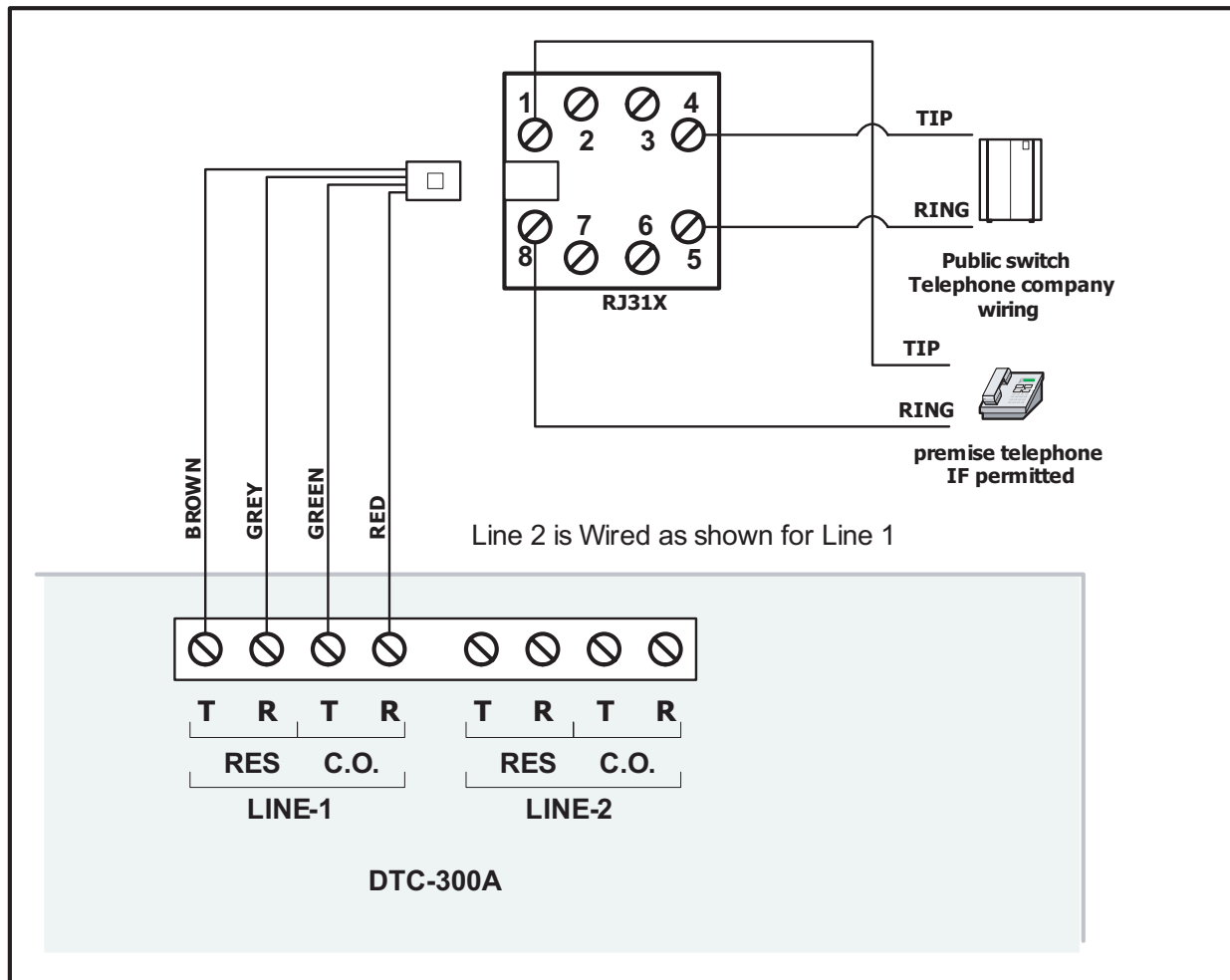

## Field Wiring (continued)

### DTC-300A MAIN BOARD INPUT ZONE WIRING

There are terminals for six input zones. Zones 1 to 6 are configurable. The default zone settings are as follows:

**Table 3: Zone Default Functions**

ZONE	DEFAULT FUNCTION
Z1	Common Alarm Input
Z2	Common Supervisory Input
Z3	Common Trouble Input
Z4	Waterflow Alarm
Z5	AC Power Trouble Input
Z6	Battery Trouble Input

Input zones 1 through 6 can be connected to the form C relay contact outputs of an associated Fire Alarm panel. These relay outputs show the status of the Fire Alarm panel as Alarm, Supervisory, Waterflow Alarm, Common Trouble, AC Power Fail Trouble and Battery Trouble. Each input zone is supervised by an 820 ohms End of Line Resistor or equivalent MP-820R/W which is a resistor on a white or red plate.

**Figure 4: DTC-300A Zone Wiring**

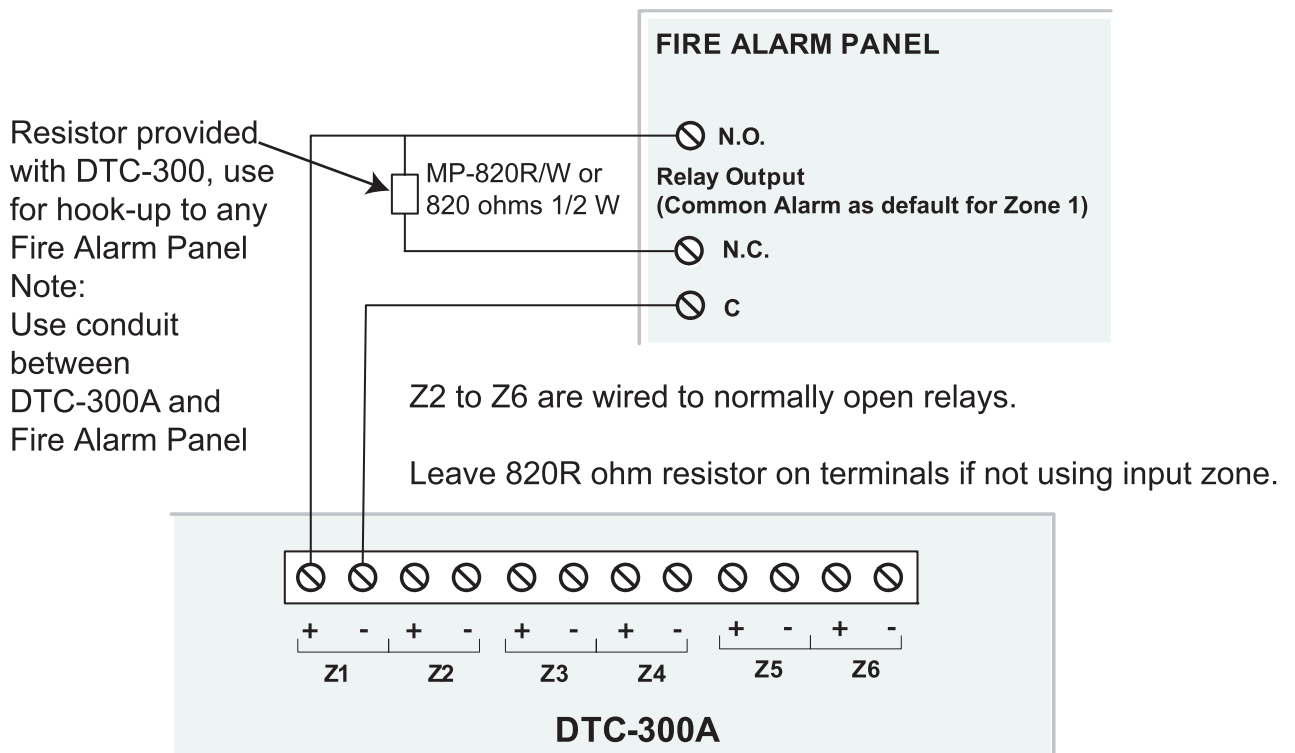

ALL INPUT ZONES ARE SUPERVISED

**Table 4: DTC-300A Zone Wiring Chart**

Wire gauge AWG	Maximum wiring run to last device	
	Feet	Meters
22	2990	910
20	4760	1450
18	7560	2300
16	12000	3600
14	19000	5800
12	30400	9200



**Notes:**

- Maximum loop resistance should not exceed 100 ohms.
- Maximum capacitance of 0.5uF total on each zone.

**TROUBLE OUTPUT WIRING**

The trouble output is wired to a Fire Alarm Trouble Only monitor zone. This is done to monitor the DTC-300A. The E.O.L resistor required for this zone is to be placed on the terminals marked E.O.L. below the Trouble Output. The value of the E.O.L. resistor depends on the FACP used. For the Mircom FACP, use 3K9 ohms. The Trouble Output terminals are dry contacts. Use JW4 to select either normally closed (pins 1 and 2) or normally open (pins 2 and 3).

**Figure 5: DTC-300A Trouble Output Wiring.**

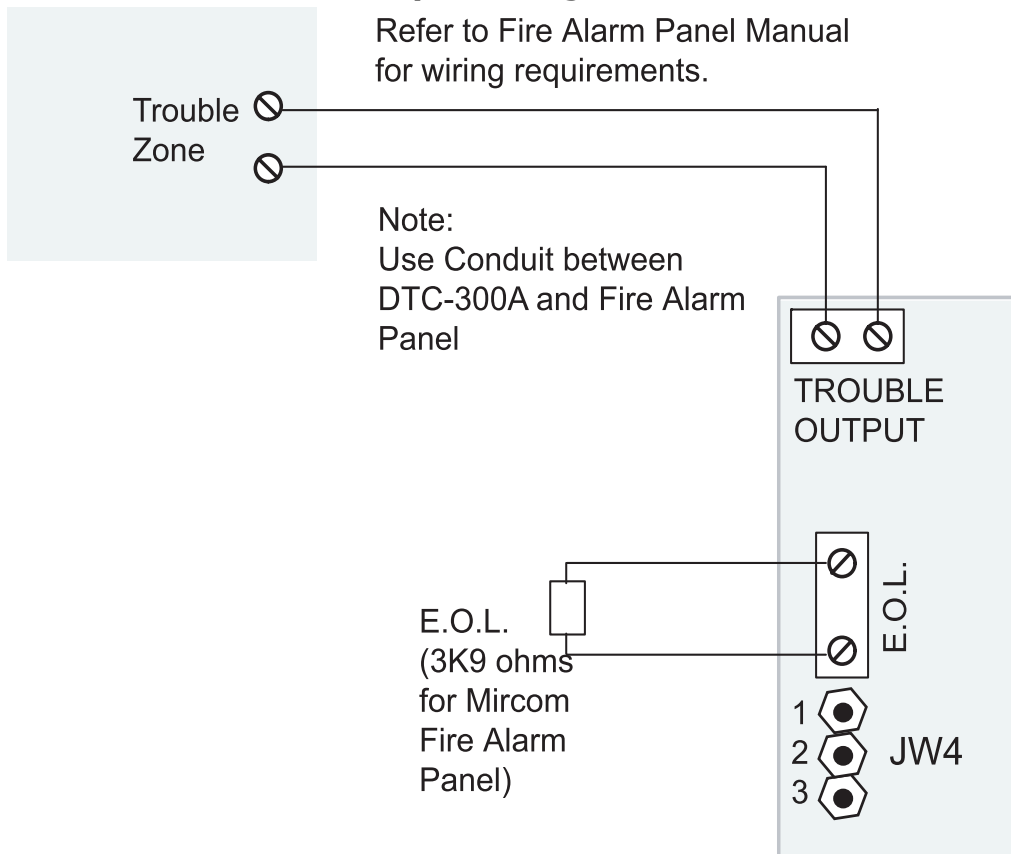

## POWER SUPPLY WIRING

The DTC-300A requires power from a 24V DC regulated or 24V DC FWR supply. Connect to terminals marked 24V DC IN, positive and negative.

**Figure 6: DTC-300A 24V Power Supply Wiring**

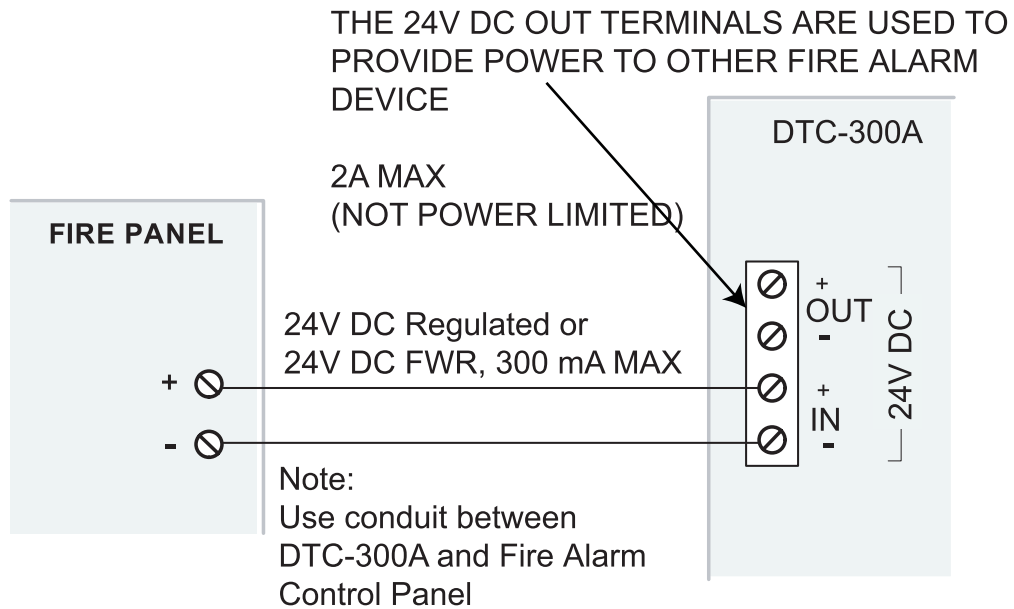

Use wire gauge for power supply wiring as specified per Table 5 below:

**Table 5: Power Supply Wiring Chart**

Wire gauge AWG	Maximum wiring run to last device	
	Feet	Meters
22	2530	770
20	3940	1200
18	5910	1800

## Power Up Procedures

1. The DTC-300A should be securely mounted on a wall. Make sure ground wire is connected.
2. Check that the telephone lines are connected as shown in Figure 3.
3. Connect the CFG-300 Configuration Tool to the U18 connector and place over the mounting studs on the DTC-300A above the key pad and secure. This CFG-300 Configuration Tool can be removed once configuration has been completed.
4. Power up the Fire Alarm Panel and the message on the CFG-300 Configuration Tool should be:

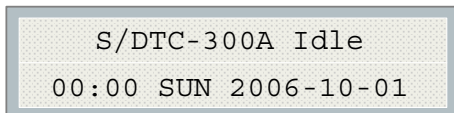

# Basic Operation and Supervision

---

The DTC-300A is able to supervise up to 6 local configurable input zones. Once the input zone is active (short condition), the corresponding event with input zone number will be reported to the monitoring station. If the input zone is open, a corresponding circuit trouble with input zone number will be reported. Each input zone can be defined as Alarm, Supervisory, Trouble, Waterflow, AC Power Trouble or Battery Trouble.

The DTC-300A is capable of reporting multiple events to a single account number, within a single call session. For a single event not yet reported, up to 4 retries will be made within a single call attempt. A failure to report to either or both accounts will generate corresponding events that will be queued for reporting. Once the DTC-300A fails to report on all telephone lines, it stops retrying, but an Alarm Event, Manual Test or 24 hour Periodic Test will force the DTC-300A to seize the line and try reporting again. For two regular Telco telephone line connections, the DTC-300A checks each line operation by reporting the 24 hour periodic test result on Line #1 or Line #2 alternately.

The DTC-300A continuously supervises the state of each of two connected Telco Lines at approximately 1 minute intervals. The regular line supervision includes DC voltage level validation and dial tone detection. Line supervision is skipped while (1) the dialer is busy reporting, (2) the modem is working or (3) there is ringing on the line. If the line supervision fails, a Line #1 or Line #2 Trouble will be reported after a 30 second verification. Once the line has been restored, a Line Trouble Restore will be reported.

## Configuration Set-up

---

There are 3 ways of configuring the DTC-300A.

1. Locally with the on-board keypad and CFG-300 Configuration Tool.
2. Locally with a Personal Computer via the RS-232 connection, a UIMA and Mircom Software MSW-012.
3. Remotely with a computer, modem, UIMA and Mircom Software MSW-012.

### CONFIGURATION VIA ON-BOARD KEYPAD

1. Connect 24V DC power supply and zone inputs from the DTC-300A to the fire alarm panel.
2. Hook up the CFG-300 Configuration Tool ribbon cable to U18 on the DTC-300A board.
3. Hook up the telephone lines and telephone as shown in Figure 3.
4. Power up the fire alarm panel and the message of the CFG-300 Configuration Tool should be:

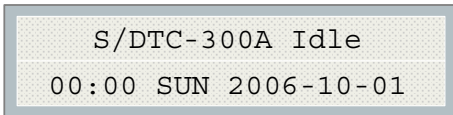

```
S/DTC-300A Idle
00:00 SUN 2006-10-01
```

5. Place jumper on JW2, located in the bottom right hand corner of the DTC-300A board (this will generate a trouble on the DTC-300A and report this to the receiver). Press Menu on the keypad to enter the configuration menu and configure the DTC-300A. The following screen will ask for the passcode.

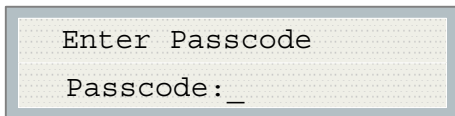

```
Enter Passcode
Passcode: _
```

6. Enter the default passcode, 1111. Press Enter.

### CONFIGURATION VIA UIMA AND COMPUTER(LOCAL):

1. Set-up UIMA connection: the 10-pin cable connector of UIMA is connected to P2 on DTC-300A board. A serial cable or USB cable is needed to connect the UIMA to the computer.
2. Place a jumper at JW2 on the DTC-300A board to allow the configuration (a trouble is generated and reported to the receiver DACR).

3. Start the Mircom Software MSW-012 on the computer to configure the DTC-300A. Follow the instructions of MSW-012 menu to complete the configuration of the DTC-300A.
4. Remove jumper on JW2 after configuration is finished, otherwise a trouble will occur.

**CONFIGURATION VIA MODEM AND COMPUTER(REMOTE):**

1. Set-up the modem connection on the computer. Make sure the phone line is working properly.
2. Place a jumper at JW2 on the DTC-300A board to allow the configuration (a trouble is generated and reported to the receiver DACR).
3. Start the Mircom Software MSW-012 on the computer to configure the DTC-300A. Follow the instructions of MSW-012 menu to complete the configuration of the DTC-300A.
4. Remove jumper on JW2 after configuration is finished, otherwise a trouble will occur.

# Keypad Configuration & Operation

The following shows the configuration at the DTC-300A using the keypad and the CFG-300 Configuration Tool. The Mircom Digital Communicator is configured by connecting the cable of the **CFG-300 Configuration Tool** to the U18 connector on the DTC-300A Main Board and placing the LCD over the 3 standoffs as shown in Figure 2.

In order to configure the DTC-300A, place a jumper on JW2, remove once configuration is complete otherwise there will be a trouble.

**To access configuration mode press the Menu button on the keypad.** The CFG-300 LCD will display the Main Menu. The keypad on the DTC-300A board and the CFG-300 is shown together in Figure 7, below.

**Figure 7: DTC-300A Configuration**

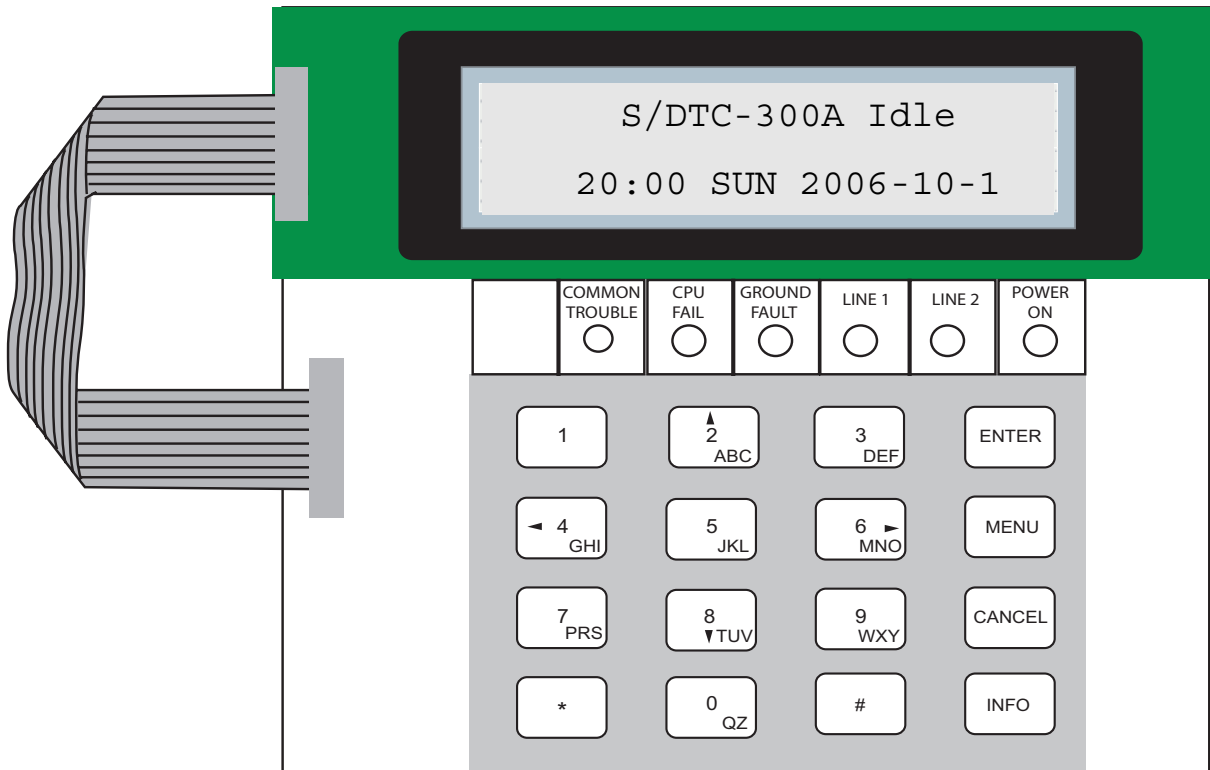

## Entering the Passcode

The programming section is passcode protected. The following image shows the message that is displayed to enter the passcode. The minimum number of digits allowed is four and the maximum allowable passcode is ten digits long; numerical values only. Press the "ENTER" key after entering the passcode. If the passcode is correct, it will take you to the main command menu. If the passcode is incorrect, the system will ask you to re-enter the passcode. The system will be exhausted after three retries and will then take you back to the Normal message display. The default password is 1111.

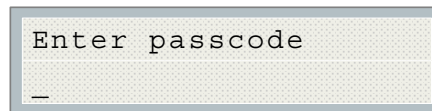

After you select a feature item by pressing the "ENTER" key, use the "UP" and "DOWN" keys to move through the different features. Use the "LEFT" and "RIGHT" keys to change the values. **To confirm the changes press the "ENTER" key.** To go one level back press the "CANCEL" key.

## Command Menu

The main command menu is pictured below. The first line of the LCD will always show “-Command Menu-“, and the second line displays the different selections. Use the “UP” and “DOWN” keys to move through the menu, and press the “ENTER” key to make a selection. To exit from the main command menu, press “CANCEL” or select the “Exit” menu option and then press the “ENTER” key.



**Note:** Command Menu feature 9 and 10 can only be accessed if jumper JW2 is placed on the main board, see Table 1.

-Command Menu-
1. View Event Log
2. Clear Event Log
3. Test Dialer
4. Config Info
5. Version Info
6. Set Time
7. Set Password
8. Default Config
9. Dialer Config
10. Input Config
11. Exit

### 1.View Event Log (Command-Menu)

-View Event Logs-
1 Remote Log
2 Local Log

Select the type of log to view. Press the “ENTER” key. The system will then show the log chosen.

Use this function to select the log to view. Either the local or remote log. The remote log contains all events associated with the fire alarm panel. The local log contains all events associated with the DTC-300A. Each log can hold up to 500 events.

Pressing the “INFO” key provides more information about the displayed event. The illustration below provides an example of how the “INFO” key works.

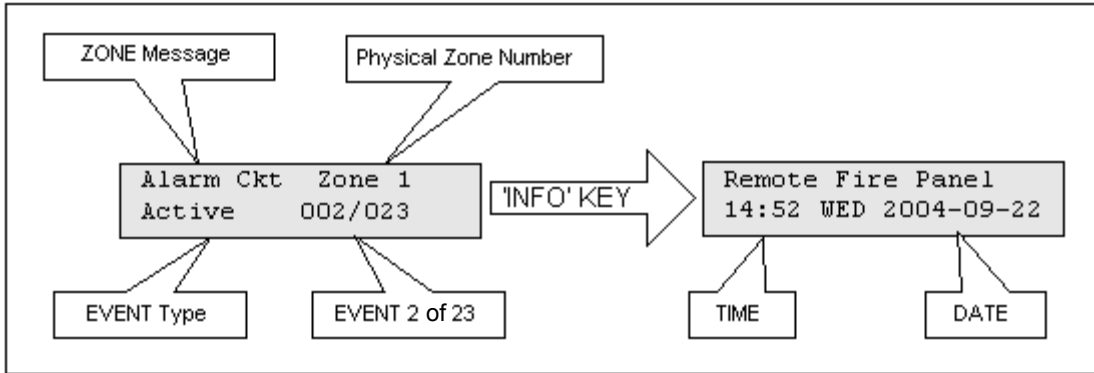

There are a maximum of 500 recent events saved in the event log. If the number of events goes beyond 500, all new incoming events will be ignored.

## 2. Clear Event Log (Command-Menu)

<pre>-Clear Log- 1 Remote Log 2 Local Log 3 All Logs</pre>	<p>Use this function to clear remote logs, local logs, or both. The remote log contains all events associated with the fire alarm panel. The local log contains all events associated with the DTC-300A. Each log can hold up to 500 events.</p>
<p>Select the type of log to clear. Press the “ENTER” key. The system will then confirm before clearing logs.</p>	
<pre>Clear all the selected log(s)? Y</pre>	
<p>Press the “ENTER” key to confirm or the “CANCEL” key to cancel the operation.</p>	
<pre>Log(s) cleared</pre>	

### 3. Test Dialer (Command-Menu)

```
-Dialer Test-
1. L#1 Manual test
2. L#2 Manual test
3. Reset Dialer
```

1.L#1 Manual test	Press Enter to test Line #1. Press Cancel to exit this menu. For a description of test messages, see <i>Dialer Test Messages</i> on the following page.
2.L#2 Manual test	Press Enter to test Line #2. Press Cancel to exit this menu. For a description of test messages, see <i>Dialer Test Messages</i> on the following page.
3.Reset Dialer	This feature flushes all reportable events from the buffer, clears all dialer troubles and resets the dialer operation. Press Enter to reset the dialer. Press Cancel to exit this menu.

#### Dialer Test Messages

The following messages will display during the test processes of Lines #1 and #2. The messages that will appear depend on the status of the dialer and the test results that are found.

Dialer idle now	The dialer is checking the line for voltage. This message automatically displays when Manual Test is selected.
No DC Volt	No DC line voltage. The line is dead or no phone line is connected or the phone line operates at abnormal voltage.
Waiting for Dialtone	The dialer is waiting for a dial tone.
Failed: No Dialtone	This message may indicate a noisy telephone line.
Dialing Receiver Now	The dial tone was detected and telephone number dialing is in process.
No DTMF tone	This message indicates that the dialer failed to send a DTMF tone.
Waiting for Acktone	Waiting for availability of the receiver. The receiver confirms the availability by sending an Ack tone.

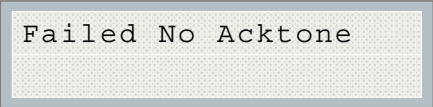
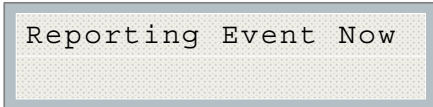
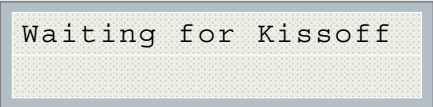
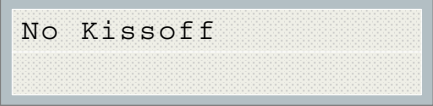
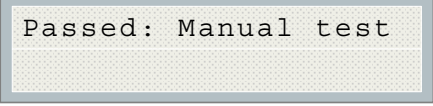
	Dialer failed to detect Ack tone. This message indicates that either the telephone number may be wrong or the receiver is not available.
	Sending events to the receiver.
	The dialer is waiting for the Kissoff tone. The Kissoff tone indicates that the receiver has received the event reports.
	No Kissoff means dialer did not detect Kissoff tone.
	The line passed the test; everything is OK.

### 4. Config Info (Command-Menu)

<pre>Configuration type: Factory default</pre> <p>Press down arrow key to see more information.</p>	<p>Configuration type will show how the panel was configured. "Factory default" means the panel has not been configured, it is as it came from the factory. "Front Panel" means it was configured at the panel. "Serial Port" means the configuration was done from a computer through the serial port. "Modem" means the configuration was completed remotely through a modem.</p>
<pre>Job Name: No job loaded</pre>	<p>If you upload a job configuration to the panel using the PC configuration utility, the job name will appear on this screen. The job name can be up to a maximum of 20 characters.</p>
<pre>Technician ID: Unknown</pre> <p>Press down arrow key for further info</p>	<p>If you upload a job configuration to the panel using the PC configuration utility, the technician's name (ID) will appear on this screen. The technician ID can be up to a maximum of 10 characters.</p>
<pre>Cfg. Date and Time: hh:mm day year:mm:dd</pre> <p>Press down arrow key for further info</p>	<p>Configuration date and time will appear for all means of configuration, thus revealing date and time configuration was last changed.</p>
<pre>Cfg. Tool S/W Vers.: Version:x.x.x.x</pre>	<p>This specifies the configuration tool version. It will display 0.0.0.0 if no PC configurator has been used.</p>

### 5. Version Info

```
S/DTC-300A
Version 1.0.1
```

The first line shows the model number and panel type and the second line shows the software version number. The version of the software is read as Major.Minor.Revision.

### 6. Set Time (Command-Menu)

```
1 Daylight Save
2 Time Clock
3 Compensation
```

<p><b>Command Menu/Set Time</b> 1. Daylight saving time</p> <pre>Daylight Saving [X] DISABLE</pre>	<pre>[X] DISABLE -&gt;Default [ ] ENABLE</pre>	<p>Use this function to enable daylight savings time.</p>
--	--	---

<p><b>Command Menu/Time Clock</b> 2. Set time and date</p> <pre>HH:MM WKD YYYY-MM-DD 00:00 MON 2000-01-01</pre>	<p>Default 00:00 MON 2000-01-01</p>	<p>Use this function to set the time and date. Use the "LEFT" and "RIGHT" keys to move the cursor to the desired location in the display and use the "UP" and "DOWN" keys to increase or decrease the values. Press the "ENTER" key to accept the changes and the "CANCEL" key to ignore the changes. <b>Note:</b> time is in 24hr format</p>
<p><b>Command Menu/Time Clock</b> 3. Compensation</p> <pre>Daily Compensation: 0</pre> <p><i>Once the compensation value is entered the display will be:</i></p> <pre>Daily Compensation: Panel Config Updated</pre>	<p>Compensation value can range from -15 to +15 seconds.</p>	<p>Use the up down arrow keys to select daily compensation value and press ENTER. For a fast clock adjust negatively. For a slow clock adjust positively. For example: for a clock which runs 5 minutes a month (based on 30 days) fast select -10 seconds.</p>

## 7. Set Password (Command-Menu)

<p><b>Command Menu/Set Password</b></p> <pre>Enter new passcode [  ]</pre> <pre>Re-enter passcode [  ]</pre> <p>If the passcode does not match, the following message appears and the system exit to the main menu</p> <pre>invalid passcode</pre> <p>If the passcode is OK the following message appears and exits to the main menu</p> <pre>Passcode updated</pre>	<p>1111 -&gt; Default</p>	<p>Use this function to change the passcode. The minimum number of digits is 4 and the maximum number is 10. ONLY numeric digits are allowed.</p>
--	---------------------------	---

## 8. Default Config (Command-Menu)

### Command Menu/Default Config

```
Load the default
settings? Y
```

Press "UP" and "DOWN" to select between Y/N. if "ENTER" is pressed the default configuration is restored.

```
Default settings
have been loaded
```

Use this function to load the default configuration in the panel.

**Warning:** By loading default configuration all the previously programmed configuration is lost permanently.

## 9. Dialer Config (Command-Menu)

Press the Menu key on the keypad of the DTC-300A board to configure the DTC-300A. The following illustration shows the dialer configuration menu. Each item in this menu is described below in detail. Use the Up and Down keys to scroll through the menu and press the Enter key to make a selection. To exit from the menu, select the Exit menu option and then press either the Enter or Cancel key. Once a menu feature has been selected, use the Left and Right keys to change values or the numerical keys to enter account numbers.

```
- Dialer Config -
1 Account Info
2 Telephone Line
3 Report Options
4 Time Parameter
5 Enable/Disable
6 Ring Detection
```

### 1. Account Info Menu

```
- Account Info -
1 Account#1 ID
2 Account#1 Tel
3 Accnt#1 Format
4 Account#2 ID
5 Account#2 Tel
6 Accnt#2 Format
```

<p><i>Command Menu/Dialer Config/Account Info</i></p> <p><b>1.Account# 1 Identification</b></p> <pre>Account#1 ID: 123456</pre>	<p>123456-&gt;Default</p>	<p>Use this function to set the Account ID for the monitoring station to which the dialer reports events. The maximum number of digits allowed is six. For contact ID, only the first four digits are used; the last two are truncated.</p> <p>If you are using the Contact ID protocol, the allowed digits for the account ID are simple digits 0 to 9 and hexadecimal digits A to F. The SIA protocol only allows digits 0 to 9.</p> <p>To enter hexadecimal digits, press the INFO button. The letter "A" will appear. To scroll through the rest of the letters, press INFO repeatedly. Press # key to move the cursor to the right or press * key to move it to the left.</p>
<p><i>Command Menu/Dialer Config/Account Info</i></p> <p><b>2.Account#1 Telephone Number</b></p> <pre>Account#1 Telnum: 101</pre>	<p>101 -&gt;Default</p>	<p>Use this function to set the telephone number of the monitoring station. The maximum number of digits allowed is 19 including commas "," and numerals. The commas will be treated as 1 sec delay. To enter a comma ",", press the INFO button. Press the # key to move the cursor to the right or press the * key to move it to the left. An example of a typical telephone number is 9,,1234567008, 9 being the dial out where required.</p>
<p><i>Command Menu/Dialer Config/Account Info</i></p> <p><b>3.Account#1 Reporting Format</b></p> <pre>ACCNT#1 Format: [X] Contact ID</pre>	<p>[X] CONTACT ID- Default [ ] SIA 300 Baud [ ] SIA 110 Baud</p>	<p>Set the reporting format that is recognized or preferred by the monitoring station.</p>
<p><i>Command Menu/Dialer Config/Account Info</i></p> <p><b>4. Account# 2 Identification</b></p> <pre>Account#2 ID: 654321</pre>	<p>654321-&gt;Default</p>	<p>Same as Account#1.</p>
<p><i>Command Menu/Dialer Config/Account Info</i></p> <p><b>5.Account# 2 Telephone Number</b></p> <pre>Account#2 Telnum: 101</pre>	<p>101 -&gt;Default</p>	<p>Same as Account#1.</p>
<p><i>Command Menu/Dialer Config/Account Info</i></p> <p><b>6.Account# 2 Reporting Format</b></p> <pre>ACCNT#2 Format: [X] Contact ID</pre>	<p>[X] ContactID-&gt;Default [ ] SIA 300 Baud [ ] SIA 110 Baud</p>	<p>Same as Account#1.</p>

## 2. Telephone Line Menu

```
- Telephone Line -
1 Line1 Dialtype
2 Line2 Dialtype
3 Line1 Dialtone
4 Line2 Dialtone
5 Num of Retries
```

<p><b>Command Menu/Dialer-Config/Telephone Line</b>  <b>1. Line#1 Dialing Type</b></p> <pre>Line#1 Dialing Type: [X] DTMF Dial</pre>	<pre>[X] DTMF Dial-&gt;Def [ ] Pulse Dial</pre>	<p>Set the dialing type for line #1  DTMF is the type recognized or preferred by the telephone company.</p>
<p><b>Command Menu/Dialer-Config/Telephone Line</b>  <b>2. Line#2 Dialing Type</b></p> <pre>Line#2 Dialing Type: [X] DTMF Dial</pre>	<pre>[X] DTMF Dial-&gt;Def [ ] Pulse Dial</pre>	<p>Same as Line#1.</p>
<p><b>Command Menu/Dialer-Config/Telephone Line</b>  <b>3. Line#1 wait for Dial tone</b></p> <pre>Line#1 Wait Dialtone [X] ENABLE</pre>	<pre>[X] ENABLE -&gt;Default [ ] DISABLE</pre>	<p>Use this function to let the system know whether or not to wait for a dial tone before dialing.</p>
<p><b>Command Menu/Dialer-Config/Telephone Line</b>  <b>4.Line#2 wait for Dial tone</b></p> <pre>Line#2 Wait Dialtone [X] ENABLE</pre>	<pre>[X] ENABLE -&gt;Default [ ] DISABLE</pre>	<p>Same as Line#1.</p>
<p><b>Command Menu/Dialer-Config/Telephone Line</b>  <b>5.Number of retries</b></p> <pre>Number of Retries: 06</pre>	<pre>06 -&gt;Default</pre>	<p>Set the number of retries for both line#1 and line#2. This function lets the dialer retry on either line if it is busy or not available. If the retry count expires, the panel reports a line trouble.</p>

### 3. Report Options Menu

```
- Report Options -
1 Alarm Prio.
2 Trouble Prio.
3 Supv. Priority
```

<p><i>CommandMenu/Dialer-Config/Report Options</i> <b>1. Alarm priority</b></p> <pre>Alarm Priority: [X] Account 1</pre>	<pre>[X] Account 1-&gt;Def [ ] Account 2</pre>	<p>Use this function to set the account priority for reporting alarms. If the priority is set for account#1 then the dialer will try account#1 first for reporting.</p>
<p><i>CommandMenu/Dialer-Config/Report Options</i> <b>2. Trouble priority</b></p> <pre>Trouble Priority: [X] Account 1</pre>	<pre>[X] Account 1-&gt;Def [ ] Account 2</pre>	<p>Use this function to set the account priority for reporting trouble. If the priority is set for account#1 then the dialer will try account#1 first for reporting.</p>
<p><i>CommandMenu/Dialer-Config/Report Options</i> <b>3. Supervisory priority</b></p> <pre>SUPV Priority [X] Account 1</pre>	<pre>[X] Account 1-&gt;Def [ ] Account 2</pre>	<p>Use this function to set the account priority for reporting supervisory troubles. If the priority is set for account#1 then the dialer will try account#1 first for reporting.</p>

### 4. Time Parameter Menu

```
-Time Parameter-
1 AC-Loss Delay
2 Cellphone Date
3 Auto-Test Time
```

<p><i>Command Menu/Dialer-Config/Time Parameter</i> <b>1.AC Loss delay</b></p> <pre>AC-Loss Delay(Hrs) 0</pre>	<pre>0 -&gt;Default</pre>	<p>Use this function to delay the reporting of AC loss trouble on the dialer for the programmed time period. Selection is from 0 to 20 hours.</p>
--	---------------------------	---

<p><b>Command Menu/Dialer-Config/Time Parameter</b>  <b>2.Cellular report date</b></p> <pre> Cellular Report Date 0         </pre>	<p>0 -&gt;Default</p>	<p>This function is not used, leave default as is at 0.</p>
<p><b>Command Menu/Dialer-Config/Time Parameter</b>  <b>3.Auto test time</b></p> <pre> Auto-Test Time 00:30         </pre>	<p>00:30 -&gt;Default</p>	<p>Use this function to set the time for auto test. This test has to be performed once a day to send the test report to the monitoring station. The time is in 24hr format, which means 00:30 is 30 minutes after midnight.</p> <p><b>Please avoid the following Test Times: 00:00, 01:55, 02:00 and 03:00</b></p>

**5. Dialer Enable/Disable**

<p><b>Command Menu/Dialer-Config/Enable/Disable</b></p> <pre> Enable/Disable [X] ENABLE  -----Warning----- Dialer Disabled!!!         </pre>	<p>[X] ENABLE -&gt;Default  [ ] DISABLE</p>	<p>The dialer is enabled by default. When the dialer is enabled or disabled, a warning message appears.</p> <p><b>Warning:</b> The dialer cannot report any event to the monitoring station if it is disabled.</p>
--	---	--

**6. Ring Detection**

<p><b>Command Menu/Dialer-Config/Ring Detection</b></p> <pre> -Ring Detect Number- [X] 5         </pre>	<p>[ ] Disabled  [ ] 1  [ ] 2  [ ] 3  [ ] 4  [X] 5-&gt;Default  [ ] 6  [ ] 7  [ ] 8</p>	<p>Use this menu item to select the number of rings on which the panel's modem will answer. The default number of rings is five. The maximum number of rings you can define is eight.</p> <p>If you select the "Disabled" option, the modem will be disabled and the panel will not pick up the incoming call.</p>
---	---	--

## 10. Input Config

```
-Input Zone Config-
1 Zone Type
2 Zone Label
```

This menu is used to program the process type and label (name) for the six input zones.

### 1. Zone Type

<p><b>Command Menu/Input Cfg/Inp Zone Config</b></p> <p><b>1. Type (Input Zone)</b></p> <pre>Zone-1 Type [X] ALARM</pre> <p><b>6.Type (Input Zone)</b></p> <pre>Zone-6 Type [X] Battery Trouble</pre>	<pre>[X] ALARM -&gt;Default [ ] SUPV [ ] TROUBLE [ ] WTR-FLOW ALM [ ] AC TROUBLE [ ] BATTERY TROUBLE</pre>	<p>Use this function to program the type of each input zone. Table 2 shows the default input types.</p>
---	--	---

### 2. Zone Name

<p><b>Command Menu/Input Cfg/Inp Zone Type</b></p> <p><b>1. Label (Input Zone)</b></p> <pre>Zone-1 Label Zone-1</pre> <p><b>6. Name (Input Zone)</b></p> <pre>Zone-6 Label Zone-6</pre>	<pre>Zone-1 ...6 -&gt;Default</pre>	<p>Use this function to set a name or label for each input zone.</p>
---	-------------------------------------	--

## 11. Exit

Pressing “ENTER” after selecting “Exit” from the main menu will return the DTC-300A to normal operation.

**ADEMCO CONTACT-ID****DTC-300A Internal Events:**

Event Description	Event Family	Qualifier	Code	Group #	Contact #
Phone Line #1 trouble detected	Trouble	New event	1 351	00	000
Phone Line #2 trouble detected	Trouble	New event	1 352	00	000
Phone Line #1 trouble restored	Trouble	Restore	3 351	00	000
Phone Line #2 trouble restored	Trouble	Restore	3 352	00	000
Failure to report to an Account	Trouble	New event	1 354	Acct #	Acct #
Report to an Account successful	Trouble	Restore	3 354	Acct #	Acct #
RS-485 Communication Trouble	Trouble	New event	1 350	00	485
Periodic (24 hr) Test Event (NORMAL)	Test	New event	1 602	00	000
Periodic (24 hr) Test Event (OFF NORMAL)	Test	New event	1 608	00	000
Manually initiated dialer test	Test	New event	1 601	00	000

**DTC-300A External Events:**

Event Description	Event Family	Qualifier	Code	Group #	Contact #
Zone Fire Alarm	Alarm	New event	1 110	00	NNN
Zone Fire Alarm restored	Alarm	Restore	3 110	00	NNN
Zone Trouble detected	Trouble	New event	1 300	00	NNN
Zone Trouble restored	Trouble	Restore	3 300	00	NNN
Zone Supervisory condition	Supervisory	New event	1 200	00	NNN
Zone Supervisory restored	Supervisory	Restore	3 200	00	NNN
Waterflow	Alarm	New event	1 113	00	NNN
Waterflow restored	Alarm	Restore	3 113	00	NNN
Indicating Zone Trouble	Trouble	New event	1 320	00	NNN
Indicating Zone Trouble restored	Trouble	Restore	3 320	00	NNN
General Alarm	Alarm	New event	1 140	00	NNN
General Alarm restored	Alarm	Restore	3 140	00	NNN
AC power lost	Trouble	New event	1 301	00	000
AC power restored	Trouble	Restore	3 301	00	000
Battery Low	Trouble	New event	1 302	00	000
Battery Low restored	Trouble	Restore	3 302	00	000
Ground Fault	Trouble	New event	1 310	00	000
Ground Fault restored	Trouble	Restore	3 310	00	000

NNN-Refers to Sensor number for zone causing event.

**SECURITY INDUSTRIES ASSOC. SIA-DCS****DTC-300A Internal Events:**

Event Description	Event Family	Qualifier	SIA Event Code	Parameter
Phone Line #1 trouble detected	Trouble	New event	LT	001
Phone Line #2 trouble detected	Trouble	New event	LT	002
Phone Line #1 trouble restored	Trouble	Restore	LR	001
Phone Line #2 trouble restored	Trouble	Restore	LR	002
Failure to report to an Account	Trouble	New event	RT	Acct #
Report to an Account successful	Trouble	Restore	YK	Acct #
RS485 Communication Trouble	Trouble	New event	YS	485
Periodic (24 hr) Test Event (Normal)	Test	New event	RP	000
Periodic (24 hr) Test Event (Off-normal)	Test	New event	RY	000
Manually initiated dialer test	Test	New event	RX	000

**DTC-300A External Events:**

Event Description	Event Family	Qualifier	SIA Event Code	Parameter
Zone Fire Alarm	Alarm	New event	FA	NNN
Zone Fire Alarm restored	Alarm	Restore	FH	NNN
Zone Trouble detected	Trouble	New event	FT	NNN
Zone Trouble restored	Trouble	Restore	FJ	NNN
Zone Supervisory condition	Supervisory	New event	FS	NNN
Zone Supervisory restored	Supervisory	Restore	FR	NNN
Waterflow alarm	Alarm	New event	WA	NNN
Waterflow alarm restored	Alarm	Restore	WH	NNN
General Alarm	Alarm	New event	QA	NNN
General Alarm restored	Alarm	Restore	QH	NNN
Indicating Zone Trouble (*)	Trouble	New event	UT	NNN
Indicating Zone Trouble restored (*)	Trouble	Restore	UR	NNN
AC power lost	Trouble	New event	AT	000
AC power restored	Trouble	Restore	AR	000
Battery Low	Trouble	New event	YT	000
Battery Low restored	Trouble	Restore	YR	000
Ground Fault	Trouble	New event	YP	000
Ground Fault restored	Trouble	Restore	YQ	000

\* SIA protocol does not define indicating zone troubles, but lists it as Untyped Zone Trouble/Restore.

## Compatible Fire Alarm Control Panels

---

**Mircom DTC-300A:** Compatible with **Mircom FA-300 Series, FX-2000 Series and FA-1000 Series** Fire Alarm Control Panels and all other FACP that can provide 24V DC regulated or 24V DC FWR power, 60mA current MIN and 110mA MAX and normally open relay contacts rated 28V DC, 2A resistive load.

## Compatible Receivers

---

The **Mircom DTC-300A** is compatible with the following **Digital Alarm Communicator Receivers (DACR)** ...

<u>DACR Receiver Model</u>	<u>Protocols</u>
SurGard MLR2 Multi-Line Receiver (ULC, ULI Approved)	SIA-DCS and Ademco Contact ID
SurGard SLR Single-Line Receiver (ULC, ULI Approved)	SIA-DCS and Ademco Contact ID
Osborne-Hoffman Quickalert! II Receiver (ULI Approved)	SIA-DCS and Ademco Contact ID
Osborne-Hoffman OH-2000 Receiver (ULI Approved)	SIA-DCS and Ademco Contact ID
Silent Knight Model 9500 Receiver (ULI Approved)	SIA-DCS and Ademco Contact ID
Radionics Model D6500 Receiver (ULI Approved)	Ademco Contact ID
Radionics Model D6600 Receiver (ULI Approved)	SIA-DCS and Ademco Contact ID

# Specifications

---

## All Circuits are Power Limited except 24V DC OUT

### **DTC-300A Digital Communicator**

- Connects to two Telephone Lines and performs line supervision.
- Connects to a FACP via input zones and 24V DC regulated or 24V DC FWR power.
- Transmits user configurable Alarm, Supervisory, and Trouble status to a DACR, using either Ademco Contact ID or SIA DCS protocols.
- User configurable locally or remotely. Configuration is passcode protected.
- Current Consumption: **Standby:** 60 mA **Alarm:** 110 mA

## Battery Calculations

---

### **DTC-300A**

The DTC-300A Battery Calculations are performed as part of the calculations for the Fire Alarm Control Panel it will be used in. See the appropriate Mircom Installation and Operation Manual.

# Warranty & Warning Information

---

## Warning Please Read Carefully

Note to End Users: This equipment is subject to terms and conditions of sale as follows:

### Note to Installers

This warning contains vital information. As the only individual in contact with system users, it is your responsibility to bring each item in this warning to the attention of the users of this system. Failure to properly inform system end-users of the circumstances in which the system might fail may result in over-reliance upon the system. As a result, it is imperative that you properly inform each customer for whom you install the system of the possible forms of failure.

### System Failures

This system has been carefully designed to be as effective as possible. There are circumstances, such as fire or other types of emergencies where it may not provide protection. Alarm systems of any type may be compromised deliberately or may fail to operate as expected for a variety of reasons. Some reasons for system failure include:

#### •*Inadequate Installation*

A Fire Alarm system must be installed in accordance with all the applicable codes and standards in order to provide adequate protection. An inspection and approval of the initial installation, or, after any changes to the system, must be conducted by the Local Authority Having Jurisdiction. Such inspections ensure installation has been carried out properly.

#### •*Power Failure*

Control units, smoke detectors and many other connected devices require an adequate power supply for proper operation. If the system or any device connected to the system operates from batteries, it is possible for the batteries to fail. Even if the batteries have not failed, they must be fully charged, in good condition and installed correctly. If a device operates only by AC power, any interruption, however brief, will render that device inoperative while it does not have power. Power interruptions of any length are often accompanied by voltage fluctuations which may damage electronic equipment such as a fire alarm system. After a power interruption has occurred, immediately conduct a complete system test to ensure that the system operates as intended.

#### •*Failure of Replaceable Batteries*

Systems with wireless transmitters have been designed to provide several years of battery life under normal conditions. The expected battery life is a function of the device environment, usage and type. Ambient conditions such as high humidity, high or low temperatures, or large temperature fluctuations may reduce the expected battery life. While each transmitting device has a low battery monitor which identifies when the batteries need to be replaced, this monitor may fail to operate as expected. Regular testing and maintenance will keep the system in good operating condition.

#### •*Compromise of Radio Frequency (Wireless) Devices*

Signals may not reach the receiver under all circumstances which could include metal objects placed on or near the radio path or deliberate jamming or other inadvertent radio signal interference.

#### •*System Users*

A user may not be able to operate a panic or emergency switch possibly due to permanent or temporary physical disability, inability to reach the device in time, or unfamiliarity with the correct operation. It is important that all system users be trained in the correct operation of the alarm system and that they know how to respond when the system indicates an alarm.

#### •*Automatic Alarm Initiating Devices*

Smoke detectors, heat detectors and other alarm initiating devices that are a part of this system may not properly detect a fire condition or signal the control panel to alert occupants of a fire condition for a number of reasons, such as: the smoke detectors or heat detector may have been improperly installed or positioned; smoke or heat may not

be able to reach the alarm initiating device, such as when the fire is in a chimney, walls or roofs, or on the other side of closed doors; and, smoke and heat detectors may not detect smoke or heat from fires on another level of the residence or building.

•*Software*

Most Mircom products contain software. With respect to those products, Mircom does not warranty that the operation of the software will be uninterrupted or error-free or that the software will meet any other standard of performance, or that the functions or performance of the software will meet the user's requirements. Mircom shall not be liable for any delays, breakdowns, interruptions, loss, destruction, alteration or other problems in the use of a product arising out of, or caused by, the software.

Every fire is different in the amount and rate at which smoke and heat are generated. Smoke detectors cannot sense all types of fires equally well. Smoke detectors may not provide timely warning of fires caused by carelessness or safety hazards such as smoking in bed, violent explosions, escaping gas, improper storage of flammable materials, overloaded electrical circuits, children playing with matches or arson.

Even if the smoke detector or heat detector operates as intended, there may be circumstances when there is insufficient warning to allow all occupants to escape in time to avoid injury or death.

•*Alarm Notification Appliances*

Alarm Notification Appliances such as sirens, bells, horns, or strobes may not warn people or waken someone sleeping if there is an intervening wall or door. If notification appliances are located on a different level of the residence or premise, then it is less likely that the occupants will be alerted or awakened. Audible notification appliances may be interfered with by other noise sources such as stereos, radios, televisions, air conditioners or other appliances, or passing traffic. Audible notification appliances, however loud, may not be heard by a hearing-impaired person.

•*Telephone Lines*

If telephone lines are used to transmit alarms, they may be out of service or busy for certain periods of time. Also the telephone lines may be compromised by such things as criminal tampering, local construction, storms or earthquakes.

•*Insufficient Time*

There may be circumstances when the system will operate as intended, yet the occupants will not be protected from the emergency due to their inability to respond to the warnings in a timely manner. If the system is monitored, the response may not occur in time enough to protect the occupants or their belongings.

•*Component Failure*

Although every effort has been made to make this system as reliable as possible, the system may fail to function as intended due to the failure of a component.

•*Inadequate Testing*

Most problems that would prevent an alarm system from operating as intended can be discovered by regular testing and maintenance. The complete system should be tested as required by national standards and the Local Authority Having Jurisdiction and immediately after a fire, storm, earthquake, accident, or any kind of construction activity inside or outside the premises. The testing should include all sensing devices, keypads, consoles, alarm indicating devices and any other operational devices that are part of the system.

•*Security and Insurance*

Regardless of its capabilities, an alarm system is not a substitute for property or life insurance. An alarm system also is not a substitute for property owners, renters, or other occupants to act prudently to prevent or minimize the harmful effects of an emergency situation.

**IMPORTANT NOTE:** End-users of the system must take care to ensure that the system, batteries, telephone lines, etc. are tested and examined on a regular basis to ensure the minimization of system failure.

## Limited Warranty

Mircom Technologies Ltd. warrants the original purchaser that for a period of two years from the date of manufacture, the product shall be free of defects in materials and workmanship under normal use. During the warranty period, Mircom Technologies Ltd. shall, at its option, repair or replace any defective product upon return of the product to its factory, at no charge for labor and materials. Any replacement and/or repaired parts are warranted for the remainder of the original warranty or ninety (90) days, whichever is longer. The original owner must promptly notify Mircom Technologies Ltd. in writing that there is defect in material or workmanship, such written notice to be received in all events prior to expiration of the warranty period.

### International Warranty

The warranty for international customers is the same as for any customer within Canada and the United States, with the exception that Mircom Technologies Ltd. shall not be responsible for any customs fees, taxes, or VAT that may be due.

### Conditions to Void Warranty

This warranty applies only to defects in parts and workmanship relating to normal use. It does not cover:

- damage incurred in shipping or handling;
- damage caused by disaster such as fire, flood, wind, earthquake or lightning;
- damage due to causes beyond the control of Mircom Technologies Ltd. such as excessive voltage, mechanical shock or
- water damage;
- damage caused by unauthorized attachment, alterations, modifications or foreign objects;
- damage caused by peripherals (unless such peripherals were supplied by Mircom Technologies Ltd.);
- defects caused by failure to provide a suitable installation environment for the products;
- damage caused by use of the products for purposes other than those for which it was designed;
- damage from improper maintenance;
- damage arising out of any other abuse, mishandling or improper application of the products.

## Warranty Procedure

To obtain service under this warranty, please return the item(s) in question to the point of purchase. All authorized distributors and dealers have a warranty program. Anyone returning goods to Mircom Technologies Ltd. must first obtain an authorization number. Mircom Technologies Ltd. will not accept any shipment whatsoever for which prior authorization has not been obtained. NOTE: Unless specific pre-authorization in writing is obtained from Mircom management, no credits will be issued for custom fabricated products or parts or for complete fire alarm system. Mircom will at its sole option, repair or replace parts under warranty. Advance replacements for such items must be purchased.

Note: Mircom Technologies Ltd.'s liability for failure to repair the product under this warranty after a reasonable number of attempts will be limited to a replacement of the product, as the exclusive remedy for breach of warranty.

## Disclaimer of Warranties

This warranty contains the entire warranty and shall be in lieu of any and all other warranties, whether expressed or implied (including all implied warranties of merchantability or fitness for a particular purpose) And of all other obligations or liabilities on the part of Mircom Technologies Ltd. neither assumes nor authorizes any other person purporting to act on its behalf to modify or to change this warranty, nor to assume for it any other warranty or liability concerning this product.

This disclaimer of warranties and limited warranty are governed by the laws of the province of Ontario, Canada.

## **Out of Warranty Repairs**

Mircom Technologies Ltd. will at its option repair or replace out-of-warranty products which are returned to its factory according to the following conditions. Anyone returning goods to Mircom Technologies Ltd. must first obtain an authorization number. Mircom Technologies Ltd. will not accept any shipment whatsoever for which prior authorization has not been obtained.

Products which Mircom Technologies Ltd. determines to be repairable will be repaired and returned. A set fee which Mircom Technologies Ltd. has predetermined and which may be revised from time to time, will be charged for each unit repaired.

Products which Mircom Technologies Ltd. determines not to be repairable will be replaced by the nearest equivalent product available at that time. The current market price of the replacement product will be charged for each replacement unit.

**WARNING: Mircom Technologies Ltd. recommends that the entire system be completely tested on a regular basis. However, despite frequent testing, and due to, but not limited to, criminal tampering or electrical disruption, it is possible for this product to fail to perform as expected.**

**NOTE: Under no circumstances shall Mircom Technologies Ltd. be liable for any special, incidental, or consequential damages based upon breach of warranty, breach of contract, negligence, strict liability, or any other legal theory. Such damages include, but are not limited to, loss of profits, loss of the product or any associated equipment, cost of capital, cost of substitute or replacement equipment, facilities or services, down time, purchaser's time, the claims of third parties, including customers, and injury to property.**

**MIRCOM MAKES NO WARRANTY OF MERCHANTABILITY OR FITNESS FOR A PARTICULAR PURPOSE WITH RESPECT TO ITS GOODS DELIVERED, NOR IS THERE ANY OTHER WARRANTY, EXPRESSED OR IMPLIED, EXCEPT FOR THE WARRANTY CONTAINED HEREIN.**

## DTC-300A INFORMATION FORM

Account #1 Identification (max. 6 digits): \_\_\_\_\_

Account #1 Telephone number (including area code): \_\_\_\_\_

Telephone number of receiving station (including area code) : \_\_\_\_\_

Reporting Format:  Contact ID

SIA

---

Account #2 Identification (max. 6 digits): \_\_\_\_\_

Account #2 Telephone number (including area code): \_\_\_\_\_

Telephone number of receiving station (including area code): \_\_\_\_\_

Reporting Format:  Contact

SIA

## Notes

---



