



Description

The Weather Stopper is a tough, clear polycarbonate cover that helps dramatically to extend the life and reliability of weather exposed manual pull stations, push buttons and similar devices as well as protect them in harsh indoor conditions. Using the same supertough cover as the Stopper® II device but without the warning horn, it is especially useful in increasing the lifespan of units in salt-water areas or other severe environments. Two versions are offered: STI-1250 for flush-mounted stations and STI-3150 for surface-mounted units.

Features

- Molded of thick, super-tough polycarbonate material
- Protection against physical damage, dust, grime, and severe environments inside and out
- Serves as an inexpensive weather cover as well as helps stop vandalism and accidental damage
- Fast, easy installation
- Widely used to extend the life of equipment in salt-water areas such as aboard ocean-going ships, on oil rigs or at beach-front condos
- UV stabilized against sun deterioration
- When used outdoors, can pay for itself many times over. (UL requires pull stations to be listed for outdoor use with cover.)
- Available in red, blue, green and yellow with custom labeling.
- UL tested to NEMA 3R requirements for weather rating for moisture resistance
- Lifetime guarantee against breakage and damage in normal usage
- Polycarbonate tested -40°F (-40°C) to 120°F (49°C)

Backed by a lifetime guarantee, this strong, durable cover can take the toughest knocks, it also guards against physical damage and thereby helps reduce false fire alarms. It is UV stabilized against discoloration and in addition protects against damage from dust and grime. Weather Stopper carries a lifetime guarantee against breakage in normal use.



Dimensions and Mounting Instructions

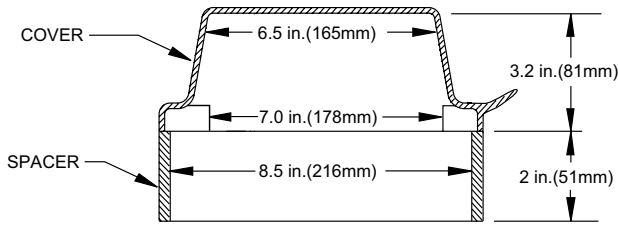

SIDE VIEW

MODELS WITHOUT HORN (STI-3150 Series)

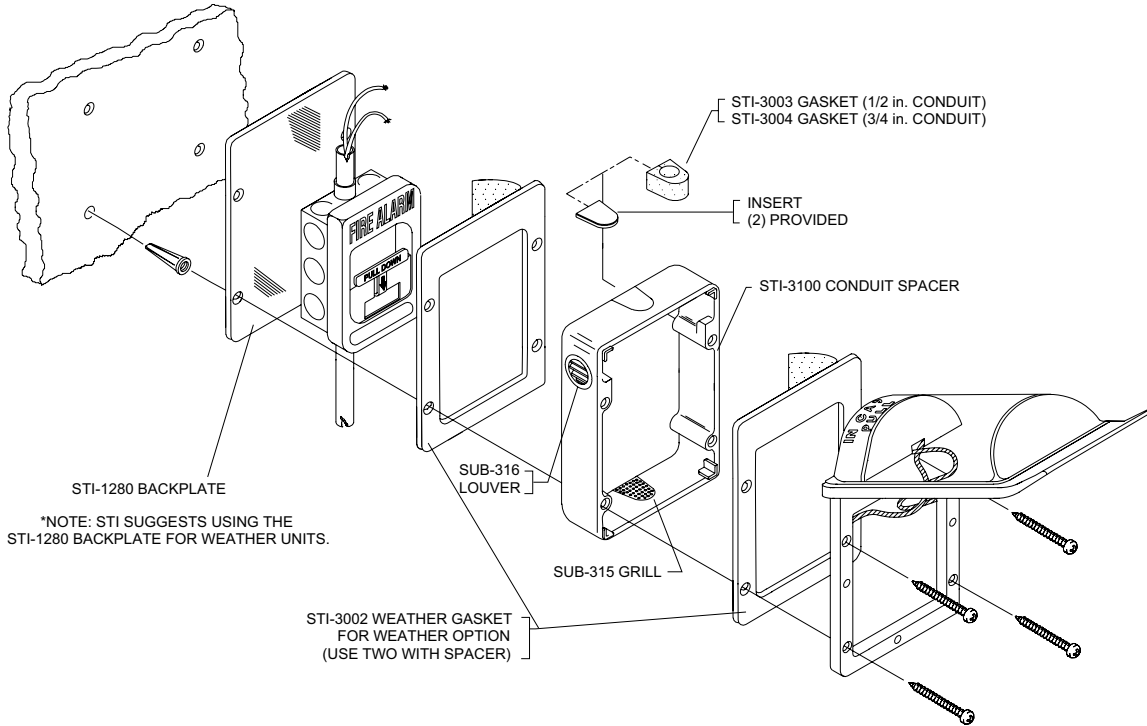
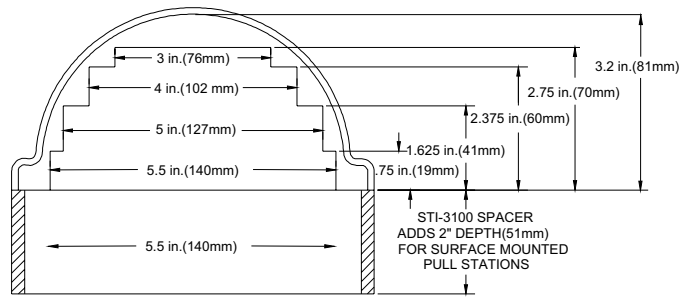

Ordering Information

Model	Description
STI-1250	Weather Stopper for flush mounting
STI-3150	Weather Stopper for surface mounting

NOT TO BE USED FOR INSTALLATION PURPOSES.



Canada

25 Interchange Way
Vaughan, Ontario L4K 5W3
Telephone: (905) 660-4655
Fax: (905) 660-4113

U.S.A.

4575 Witmer Industrial Estates
Niagara Falls, NY 14305
Toll Free: (888) 660-4655
Fax Toll Free: (888) 660-4113

Web page: <http://www.mircom.com>

Email: mail@mircom.com

Distributed by:



CAT. 5311
Rev. 2