



## Features

- Proven effective for more than 20 years in helping stop false fire alarms without restricting legitimate alarms
- Lifetime guarantee against breakage of polycarbonate housing (one year on electronic components)
- Can be used as a guard against physical damage to a manual pull station, with or without the optional warning horn
- Cover is UV stabilized against sun deterioration
- Optional horn has choice of 95 dB or 105 dB at 1 foot
- Available in red, blue, green or yellow with custom labeling
- Larger sizes and surface mounted pull stations accommodated with STI-3100 conduit spacer.
- Polycarbonate tested -40°F (-40°C) to 120°F (49°C)
- Weather resistant gaskets available
- When covering a pull station outside, UL requires stations to be listed for outdoor use with cover
- Tested and accepted by fire prevention authorities and approved by testing organizations
- Power source is 9 VDC alkaline battery on standard Stopper II. (Remote powered unit is available)
- Fits virtually all manual pull stations

## Description

The Stopper II is a unique and patented device that has been helping stop false fire alarms around the world for more than 20 years, without restricting legitimate alarms. It offers excellent protection against physical damage (both accidental and intentional), dust and grime as well as severe environments inside and out. It is ideal for schools, colleges, hospitals, nursing homes, stores, hotels and public buildings of almost every kind where there is a threat of false fire alarms.

The Stopper II consists of a clear, tamper-proof, supertough polycarbonate shield and frame that fits over manual pull stations. When lifted to gain access to the actual alarm, it sounds a piercing self-contained 95 dB or 105 dB warning horn (at 1 foot). Immediate attention is drawn to the area and a prankster will either run or be caught.



## Dimensions and Mounting Instructions

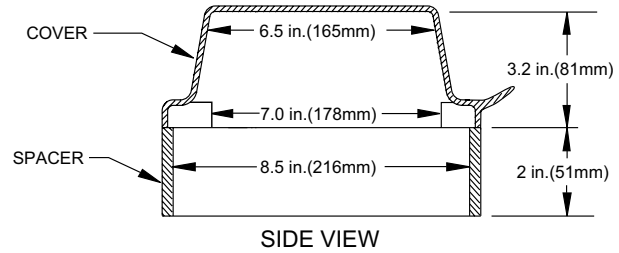
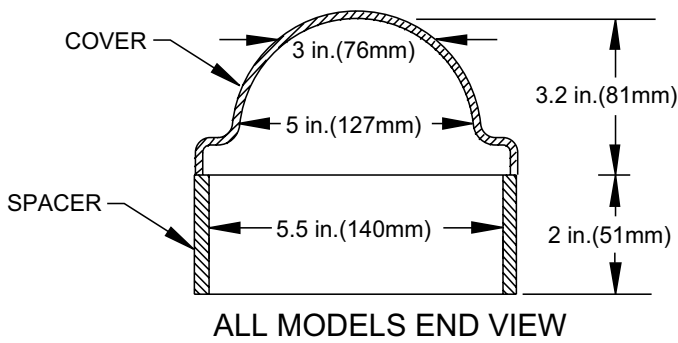

### MODELS WITHOUT HORN (STI-1200 Series)

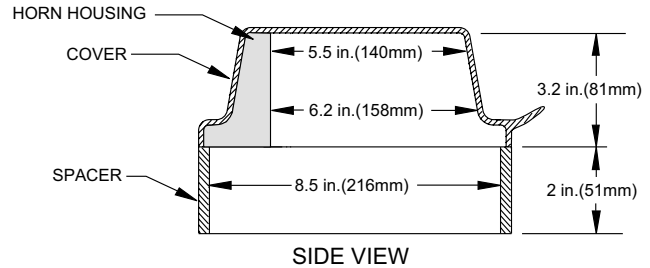

### MODELS WITH HORN (STI-1100 Series)

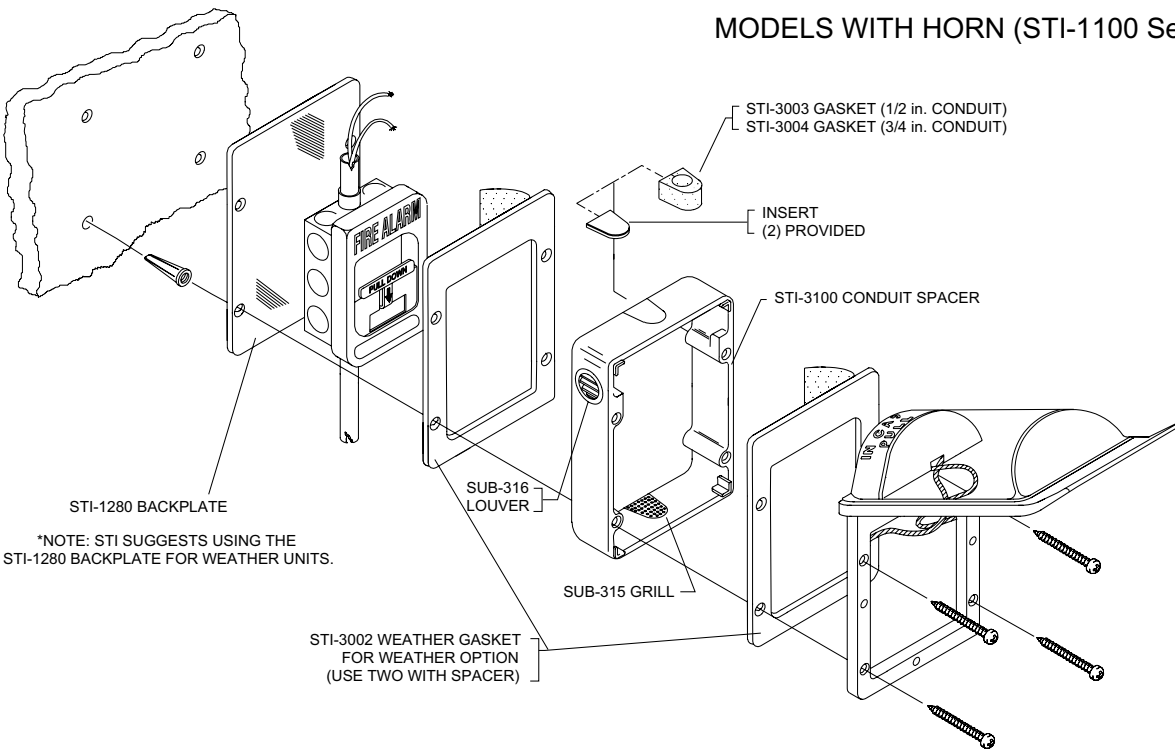

## Ordering Information

Model	Description
STI-1100	Stopper II with Horn for flush mounting
STI-1130	Stopper II with Horn for surface mounting
STI-1200	Stopper II without Horn for flush mounting
STI-1230	Stopper II without Horn for surface mounting

NOT TO BE USED FOR INSTALLATION PURPOSES.



### Canada

25 Interchange Way  
Vaughan, Ontario L4K 5W3  
Telephone: (905) 660-4655  
Fax: (905) 660-4113

### U.S.A.

4575 Witmer Industrial Estates  
Niagara Falls, NY 14305  
Toll Free: (888) 660-4655  
Fax Toll Free: (888) 660-4113

Web page: <http://www.mircom.com> Email: [mail@mircom.com](mailto:mail@mircom.com)

Distributed by:

ISO 9001:2000  
REGISTERED



CAT. 5310  
Rev. 2